



Installation Manual

The 12V Direct Response Auto-Retract System may be installed as part of the original motorized awning installation or as an upgrade to an existing motorized awning installation. In addition, an optional RF wireless remote may be included at time of installation or added after the installation.

The system offers unique features not available with a standard awning installation.

- 1) Full Retract – When the awning is retracted, it retracts completely. It is not necessary to hold the button when closing the awning.
2) Full Extend – When the awning is extended, it extends completely. It is not necessary to hold the button when opening the awning.
3) Auto-Retract – The awning can be set to automatically close when windy conditions occur.
4) Remote Control – The operator can conveniently operate the awning from any location.

TABLE OF CONTENTS

Installation 3
Prior to Installing the Kit.....3
Installing the Sensor4
Installing the Switches6
Wiring an Additional Patio Switch.....6
Installing the Direct Response Control Box7
Wiring Diagram – Direct Response8
Ignition Lockout Sensor Installation (Optional)9
Installing the Remote Receiver.....9
Programming the Receiver.....10
Operational Notes:10
Testing the System 11
Testing Standard Operation.....11
Testing Auto-Retract Operation11
Testing the Key FOB12
Limited Warranty.....12

SAFETY INFORMATION

⚠ WARNING

A WARNING INDICATES A POTENTIALLY HAZARDOUS SITUATION WHICH , IF NOT AVOIDED, COULD RESULT IN DEATH OR SERIOUS INJURY AND/OR MAJOR PROPERTY DAMAGE.

⚠ CAUTION

A CAUTION INDICATES A POTENTIALLY HAZARDOUS SITUATION THAT MAY CAUSE MINOR TO MODERATE PERSONAL INJURY AND/OR PROPERTY DAMAGE. IT MAY ALSO BE USED TO ALERT AGAINST UNSAFE PRACTICES.

NOTE: A note indicates further information about a product, part, or step.

Tip: A tip provides helpful suggestions.

COMPONENT CHECKLIST

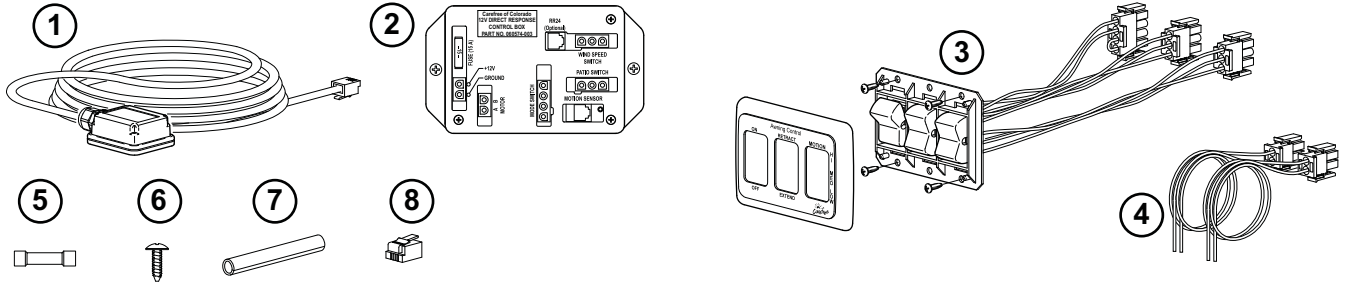

Remote Control Kit (ordered separately)

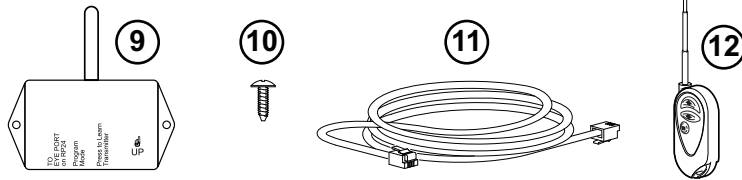

Ignition Lock-Out Kit (ordered separately)

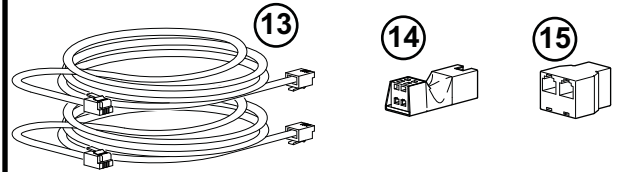

DR004

<input checked="" type="checkbox"/>	ITEM	DESCRIPTION		QTY	NOTE
<input type="checkbox"/>	1	Sensor Assy, Motion		1	
<input type="checkbox"/>	2	Control Box, Direct Response		1	
<input type="checkbox"/>	3	Switch Kit (includes bezel and connector harnesses)		1	
<input type="checkbox"/>	4	Harness, Power, Motor		2	
<input type="checkbox"/>	5	Butt Splice, 14-16 AWG		4	
<input type="checkbox"/>	6	Screw, Phillips Truss Head	#6 x 1/2	10	
<input type="checkbox"/>	7	Cord Retainer	2"	8	
<input type="checkbox"/>	8	Plug, Modular, RJ-11 4-Conductor		1	
<input type="checkbox"/>	9	Receiver, RF, 433 MHz, RR Version 2		1	
<input type="checkbox"/>	10	Screw, Phillips Truss Head	#6 x 1/2	2	
<input type="checkbox"/>	11	Cable	60"	1	3
<input type="checkbox"/>	12	Remote Control Key FOB, 433MHz		1	1
<input type="checkbox"/>	13	Sensor, Ignition Lock-Out			2,3
<input type="checkbox"/>	14	Splitter			2

- NOTES:
1. Additional remote control key FOBs may be ordered separately.
 2. The optional ignition lockout and splitter (items 18, 19) must be ordered separately. Two versions of the lock-out sensor are available. See page 9 for description.
 3. The optional ignition lockout uses 2 additional cables (item 16).

INSTALLATION

PRIOR TO INSTALLING THE KIT

For New Installations – These instructions assume that the awning and arms have been mounted and that the cable(s) from the arms have been routed through the exterior wall as described in the awning installation instructions. These instructions replace the switch and wiring directions included with the awning.

For Existing Installations – The installer must locate and remove any existing control boxes and switches (not including the exterior switch with the Eclipse). Access to the motor cable(s) and the 12VDC/Ground wires is required.

1. Determine the location of the switches and control box:
 - 1.1 Do not mount the control box and switches near heat producing elements such as LP appliances or engine exhaust components.
 - 1.2 The mounting surface for the switch plate should be a minimum of 1/2" thick.
 - 1.3 The clearance dimensions for the switch plates are shown in Figure 3 on page 6.
 - 1.4 Mount the control box near the switch panel so that the switch harnesses can be plugged into the control box without stressing the connections. The switch harness length is 72", control box dimensions are shown in Figure 4 on page 7.
2. Determine the location of the optional RF receiver:
 - 2.1 Do not mount the receiver near heat producing elements such as LP appliances or engine exhaust components.
 - 2.2 For best reception, do not mount the receiver near or on a metal surface.
 - 2.3 Mount the unit with the antenna pointing up.
 - 2.4 The clearance dimensions for the receiver are shown in Figure 6 on page 9.
 - 2.5 The included cable is approximately 60 inches long. Mount the unit close enough to the control box so that the cord can be connected without stressing the connections.

CAUTION

ALWAYS DISCONNECT THE VEHICLE BATTERY AND ELECTRICAL SOURCES BEFORE WORKING WITH THE ELECTRICAL WIRING AND COMPONENTS.

When the *Direct Response* installation is complete return to the original awning instructions for any final assembly required.

INSTALLING THE SENSOR

This section is for fitting the motion sensor into the arm of an existing installation. If the sensor has been previously installed, go to "Installing the Switches" on page 6.

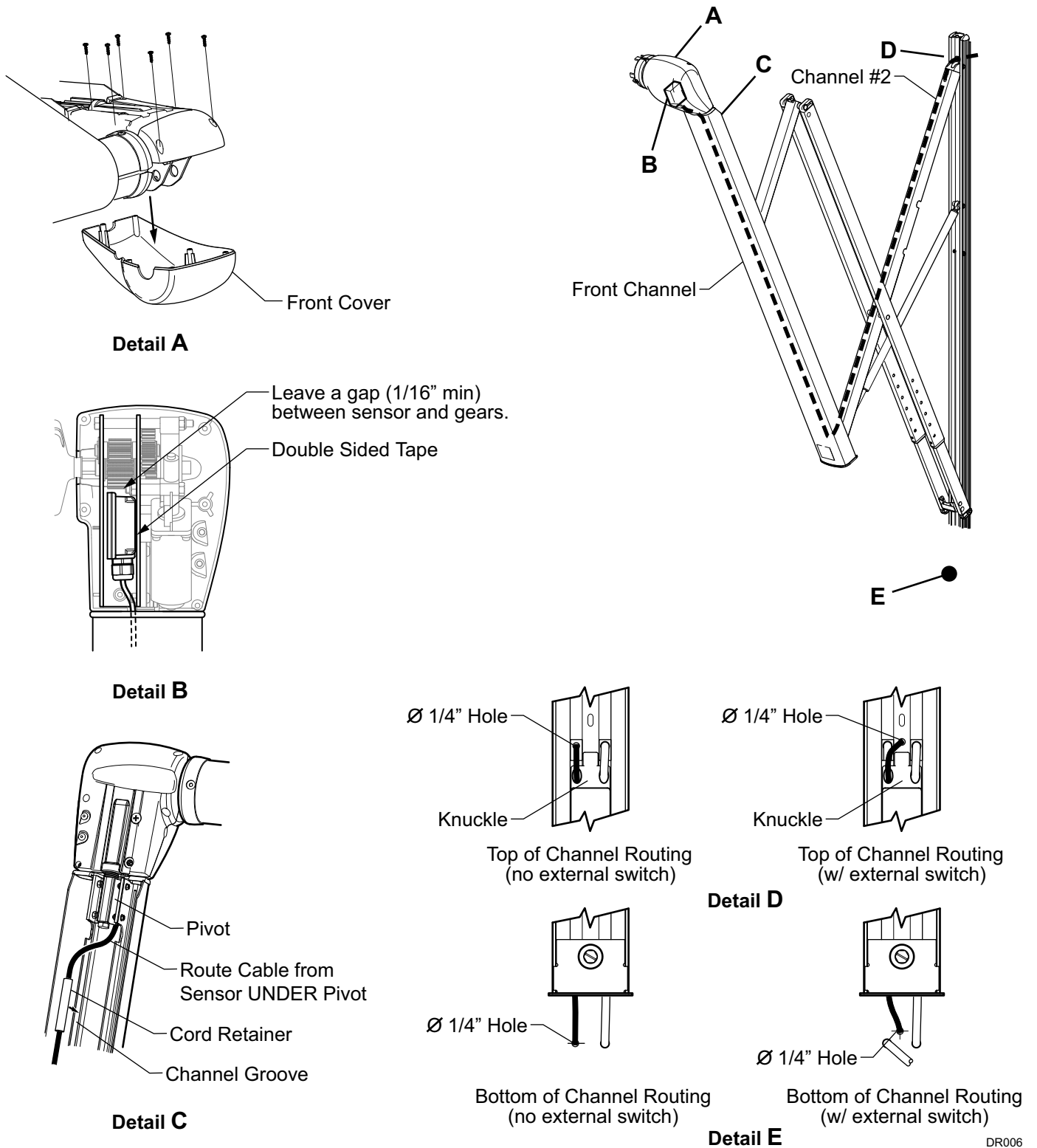

Figure 1. Mounting the Sensor.

DR006

1. Open the awning. The awning must be opened far enough to allow access to the back of the front channel and channel #2.
2. *(Detail A)* Remove the front cover. There are six (6) small screws through the back cover, do not remove the larger screw toward the center.
3. *(Detail B)* Clean the inner face of the bracket. Then remove the release paper from the double sided tape on the sensor. Position the sensor as shown and firmly press against the inside face of the bracket. Ensure that the sensor does not touch the gears and that it is far enough inside to allow the front cover to be installed.
4. Cut off the existing connector from the cable and discard.
5. *(Detail C)* Route the cable into the front channel under the pivot block.
6. Place a cord retainer onto the cable and press into the open channel groove. Ensure that the open side of the retainer is facing in toward the channel. Repeat 4 more times down the length of the front channel.
7. At the pivot joint, slip the cable into channel #2 under the shock mount.
8. Place a cord retainer onto the cable and press into the open channel groove. Repeat 3 more times up the length of channel #2.

NOTE: The cable crosses from one side of the front channel to the opposite side of channel #2. This allows the cable to flex when the arm is opening or closing.

9. Slip the cable through the open hole in the knuckle at the top of channel #2.
10. *(Details D, E)* In the area shown, drill a 1/4" hole into the coach. Route the cable into the coach and to the control box location.

NOTE: For bottom routings, loosen the attaching screws for the arm. Slip the cable through the access hole at the top of the mounting channel and pull down. Lightly pull the cable at the bottom and align with the rear channel groove. Tighten the attaching screws for the arm.

11. At the control box location, use a 4 conductor modular plug crimp tool to install a new RJ-11 4-conductor plug. **THE CABLE AND PLUG MUST BE ORIENTED AS SHOWN FOR PROPER SYSTEM OPERATION.**

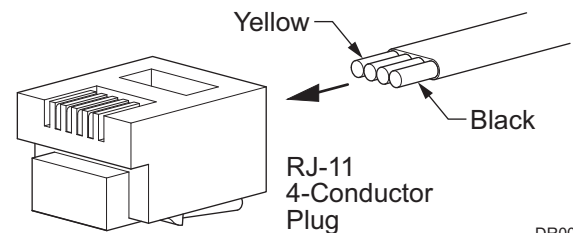

DR007

Figure 2. Cable End.

INSTALLING THE SWITCHES

1. At the switch location cut a 3.5" [8.9cm] x 1.5" [3.8cm] hole
2. Push the wires and switches into the hole then attach the switch frame using four (4) #6 x 1/2" screws.

⚠ CAUTION

ENSURE THAT THE SWITCHES ARE ORIENTED WITH THE ON/OFF SWITCH ON THE LEFT TO MATCH THE FACEPLATE LABELS FOR THE SWITCH IDENTIFICATION AND ORIENTATION

Tip: Drilling a small pilot hole for the screws will reduce the chance of splitting or stripping out the hole with the screws.

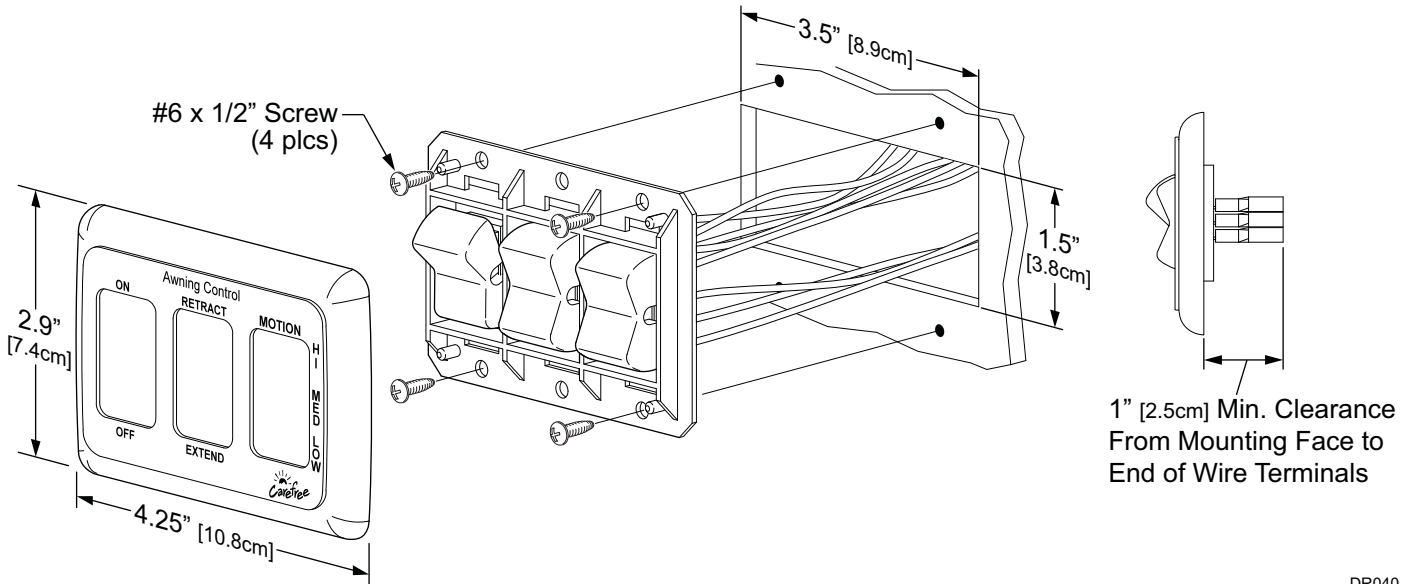

DR040

Figure 3. Mounting the Switches.

Wiring an Additional Patio Switch

This section is for wiring an additional PATIO switch and for Eclipse models with an exterior switch.

(refer to the wiring diagram on page 8)

1. Route the switch wires to the main switch location.
2. Splice the wires in parallel with the EXTEND/RETRACT switch wires. Pin 1 of the additional switch should go to pin 1 of the main patio switch etc.

INSTALLING THE DIRECT RESPONSE CONTROL BOX

1. Position the control box and secure using two (2) #6 x 1/2" screws.
2. Attach the switch harness connectors to the box at the positions labeled on the box. Press the connectors in until the tabs click into place to ensure a solid connection.
3. Run a 12 gauge wire (never use less than 14 gauge) from the power distribution panel (auxiliary battery circuit) or equivalent.
4. Run a wire to chassis ground. Suitable ground would be the vehicle chassis or conductive structure connected to the chassis.
5. Connect a two-wire harness to the control box in the position marked +12V/GROUND.
6. Splice the wires from steps 2 and 3 to the harness. Carefully note the labeling on the box so that the 12V power goes to the 12V pin and the ground goes to the pin labeled ground.
7. Connect a two-wire harness to the control box in the position marked MOTOR.
8. Run the motor cable from the awning to the control box. Splice the wires to the connector harness in step 7. The red wire should go to Pin marked "B" and the black goes to the pin marked "A".

NOTE: During testing, it may be necessary to reverse these wires (red to B, black to A) if the awning extend and retract functions are reversed.

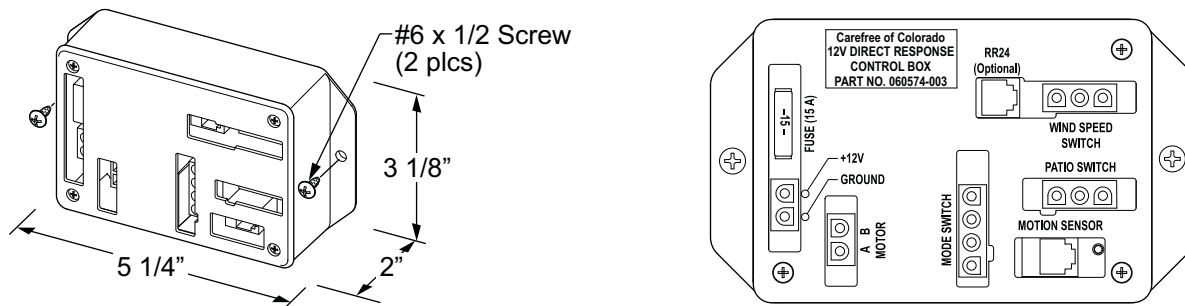

DR008

Figure 4. Mounting the Direct Response Control Box.

WIRING DIAGRAM – DIRECT RESPONSE

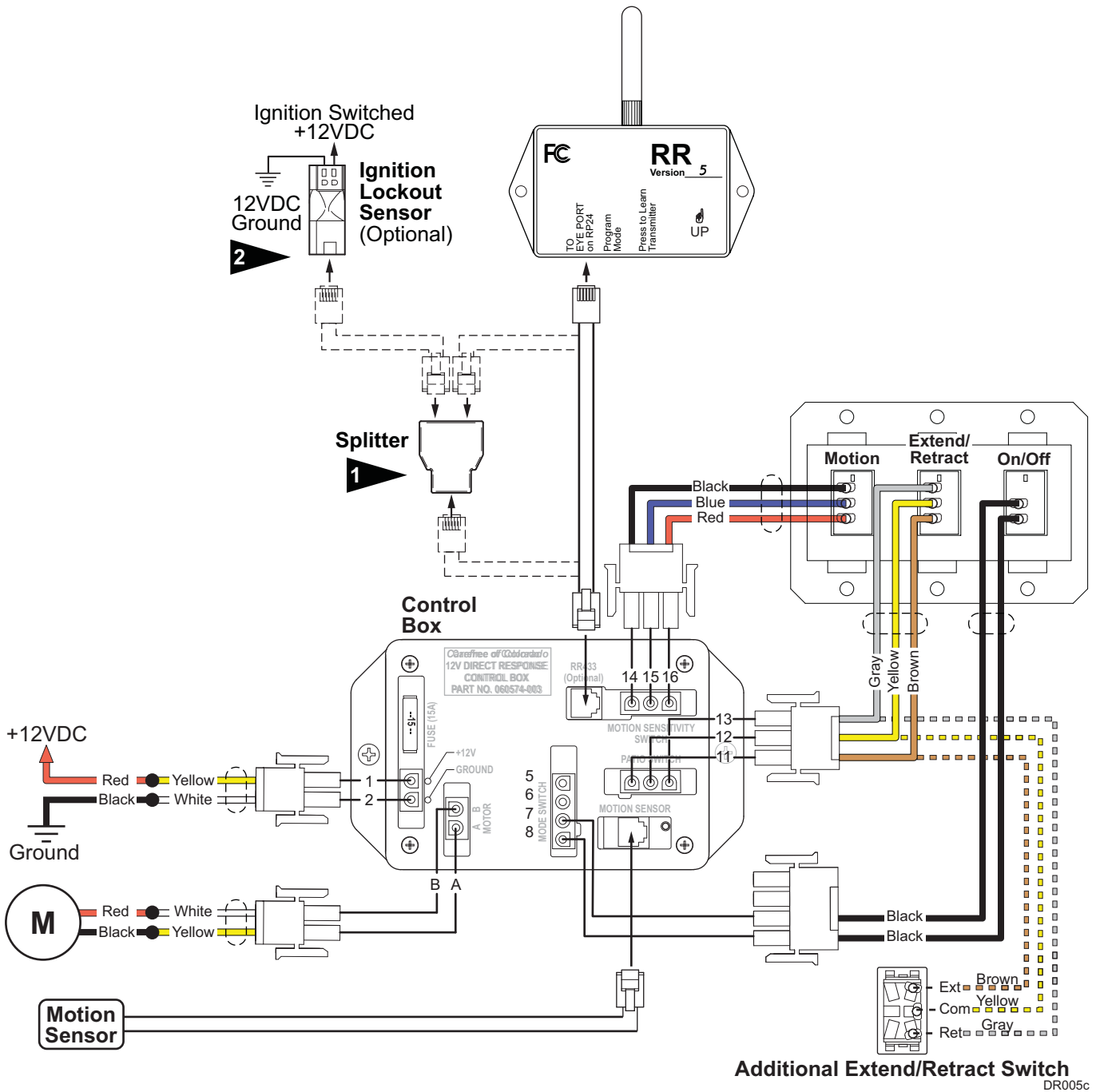

NOTES:

1 Early versions of the Eclipse Exterior Switch cable may have different wire colors.

	Current Color	Previous Color
Jacket Color:	Black or White	Gray
Wire Colors:	Brown	Black1
	Gray	Black2
	Yellow	Yellow/Green

2 Splitter is used only when the optional Lock-Out Sensor is installed. Connect the RF receiver directly to the control box if Lock-Out is not installed.

3 The optional Lock-Out Sensor can only be used with control boxes marked "060574-003" or higher. Wires for the sensor are not pin specific.

Figure 5. System Wiring Diagram.

IGNITION LOCKOUT SENSOR INSTALLATION (OPTIONAL)

The optional STD ignition lockout will disable the extend function when the module receives a current through a switched 12VDC circuit.

A switched 12VDC source is a line that is "hot" when the ignition switch is in the on position; or, a 12VDC circuit through a relay that is "hot" when a specific condition is met (i.e. releasing the parking brake). Relays are furnished by the installer.

(Refer to the wiring diagram on page 8)

1. Disconnect power to the awning. Disconnect the battery or pull the appropriate circuit breaker.
2. Locate the control box for the Direct Response System.

NOTE: The 6" cable and splitter are for systems with a remote. If there is no remote, attach the 60" cable to the module; plug the other end of cable directly to the "RR24" port in the control box. Then proceed with step 8.

3. If there is a remote receiver, disconnect the cable from the "RR24" port in the control box. Do not disconnect the cable from the receiver box.
4. Connect the supplied 6" cable to "RR24" port in the control box.
5. Attach the splitter to the other end of the cable.
6. Plug the cable from the remote receiver into the splitter.
7. Attach the Lock-Out Sensor to the end of the 60" cable. Route the cable as desired and connect the cable to the splitter.

NOTE: Wires to the module are not pin specific.

8. Attach one 18-gauge wire to a terminal of the sensor and route the wire to a suitable 12VDC ground.
9. Attach a second 18-gauge wire to the second terminal of the sensor and route the wire to a SWITCHED 12VDC source.

A switched 12VDC source is a line that is "hot" when the ignition switch is in the on position; or, a 12VDC circuit through a relay that is "hot" when a specific condition is met (i.e. releasing the parking brake). Relays are not furnished with this kit.

10. Bundle and secure the sensor, cable and wires as required.

INSTALLING THE REMOTE RECEIVER

1. Determine the location of the optional RF receiver:
 - 1.1 Do not mount the unit near heat producing elements such as LP appliances or engine exhaust components.
 - 1.2 For best reception, do not mount the unit near or on a metal surface.
 - 1.3 Mount the unit with the antenna pointing up.
 - 1.4 The included cable is approximately 60 inches long. Mount the unit close enough to the control box so that the cord can be connected without stressing the connections.

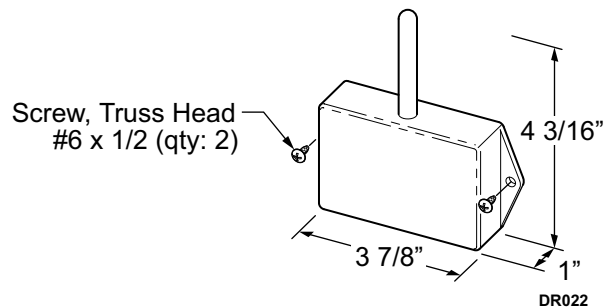

Figure 6. Mounting the RF Receiver.

- 1.5 Allow room below the box to access the connector jack, programming button and indicator light.
2. Position the control box and secure using two (2) #6 x 1/2" screws.

NOTE: If the box is mounted on a surface that is less than 1/2" thick, the screws will protrude through the opposite side of the surface.
3. Connect the cable to the receiver.
4. If using the Ignition Lockout Sensor, route the cable to the splitter and connect. If not using the sensor connect the cable directly to the control box

Programming the Receiver

These instructions apply to the current 433 MHz configuration of the remote and receiver. For older versions (418 MHz) refer to the Eclipse Service Manual listed on page 12.

1. Power to the control box must be on.
2. Press and release the "Press to Learn Transmitter" button on the bottom of the receiver box. The receiver is in program mode when the red light comes on.
3. Press and release the stop button on the remote. The red light will go out after the receiver learns the remote signal.

NOTE: Pressing the stop button will cause the blue up arrow button to default as the close (retract) function.

If a function button is pressed to train the receiver, it will be programmed as the close (retract) button. Example: Pressing the bottom button will program the bottom button for retract and the top button as extend.

4. Repeat for each additional remote.

Operational Notes:

- Transmitter and receiver operate on a frequency of 433 MHz.
- The receiver exits the program mode after ten seconds.
- If the light does not come on above, the memory is full and must be cleared. If the light still does not come on, check the continuity of the cord between the boxes and repair or replace as required. Pin 1 of the 1st connector goes to pin 1 of the 2nd connector etc.
- If the light does not go out in above, the receiver already knows the transmitter's signal or the battery in the remote needs to be replaced.
- To clear the memory: PRESS AND HOLD the transmitter learn button. While holding the button, the indicator light should be OFF for the full 5 seconds then come on.
- The system may be programmed for up to 5 remotes. Additional remotes may be ordered separately.

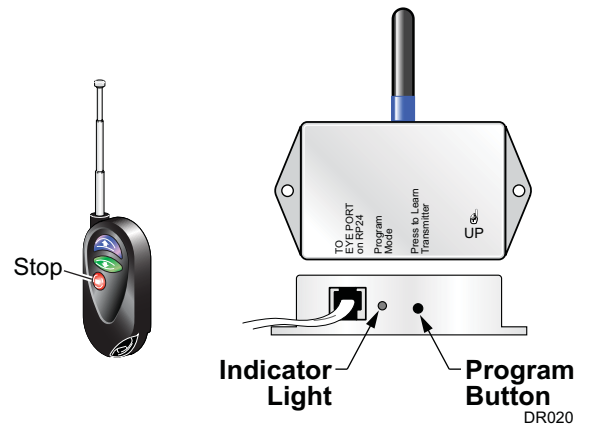

TESTING THE SYSTEM

Ensure that the operator can see the awning during the tests or has a helper that can see the awning.

Definitions: *Manual* – the motor runs only while the switch is pressed.

Automatic – the motor continues to run after the button is released.

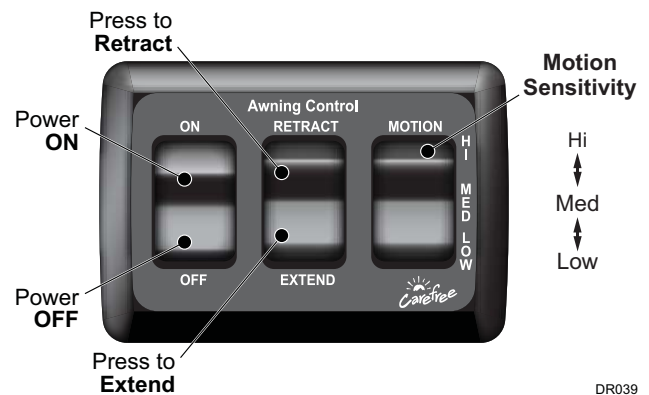

Figure 7. Control Switches.

DR039

TESTING STANDARD OPERATION

⚠ CAUTION

THE RETRACT FUNCTION IS AUTOMATIC AND WILL CONTINUE UNTIL THE AWNING IS FULLY RETRACTED. ENSURE THAT DURING TESTING AND OPERATION, NO OBSTACLES OR PEOPLE ARE IN THE WAY OF THE AWNING.

1. Turn the Power switch to the OFF position and restore vehicle power.
2. Press and hold the PATIO switch in the EXTEND position. The awning should not move.
3. Press and release the PATIO switch in the RETRACT position. The awning should not move.
4. Turn the Power switch to the POWER ON position.
5. Press and release the PATIO switch in the EXTEND position. The awning should extend automatically. Allow the awning to extend for 2-3 seconds then press and release the PATIO switch a second time to stop the awning.

STOP: If the awning does not move or functions differently than described above, set the Power switch to the off position.

6. Press and release the PATIO switch in the RETRACT position. The awning should retract automatically. Allow the awning to retract for 2-3 seconds then press and release the PATIO switch a second time to stop the awning.

STOP: If the awning does not move or functions differently than described above, set the power switch to the off position.

7. Press and release the PATIO switch in the RETRACT position. The awning should retract automatically until it is completely closed. The motor should stop when the awning is fully retracted.

For troubleshooting/diagnostics of the 12V Direct Response refer to the Eclipse Service Manual available on-line @carefreeofcolorado.com

TESTING AUTO-RETRACT OPERATION

NOTE: These tests will use the MOTION switch.

Hi is the least sensitive.

Low is the most sensitive.

1. Set the Power switch to ON.
2. Set the Motion switch to LOW.
3. Fully extend the awning using the PATIO switch.
4. Create a firm but gentle rocking motion vertically with the leading edge of the awning. The awning should retract after 2-3 seconds of motion.

TESTING THE KEY FOB

Prior to testing the remote control Key FOB, the Direct Response system must be fully installed, tested and operational. If the system has not been tested, go to "Testing the System" on page 11 before continuing this section.

1. Ensure that power is on to the system control box.
2. Extend the awning out about half way.
3. Set power switch to "OFF".
4. Press each button on the Key FOB. The awning should not move.
5. Set the power switch to "ON".
6. Press and hold the EXTEND button on the Key FOB for 2 to 3 seconds; then release the button. The awning should extend out until the button is released
7. Press and release the RETRACT button on the Key FOB. The awning should retract automatically.



Figure 8. Key FOB Test.

CAUTION

THE RETRACT FUNCTION IS AUTOMATIC AND WILL CONTINUE UNTIL THE AWNING IS FULLY RETRACTED. ENSURE THAT DURING TESTING AND OPERATION, NO OBSTACLES OR PEOPLE ARE IN THE WAY OF THE AWNING.

8. While the awning is retracting, press and release the STOP button on the Key FOB. The awning should stop when the button is pushed.

NOTE: The retract function will also stop if the extend or retract buttons are pushed once.

LIMITED WARRANTY

Carefree of Colorado (hereafter referred to as Carefree) warrants to the FIRST retail Purchaser that the 12V Direct Response System is free of defects in material and workmanship for one (1) year from original date of purchase.

This warranty does not apply to damages that are the result of improper installation, misuse or neglect. In addition, wear and fading from normal use is excluded from this coverage.

WARRANTY CLAIM PROCEDURE

1. Retain a copy of the original purchase receipt.
2. If the product is found defective within the warranty period, return the product along with the original purchase receipt to your qualified Carefree dealer.
3. All returns are for product replacement only. No returns for cash or credit are accepted.
4. Carefree does not cover any costs associated with delivery or return of the product.

Reference Publications located @ www.carefreeofcolorado.com:

052547-001	Eclipse Arms and Canopy After Market Installation Manual
052547-021	Eclipse Arms and Canopy OEM Installation Manual
052547-101	Eclipse Arms Upgrade for One-Touch
052547-221	Eclipse Owner's Manual
052547-301	Eclipse Service Manual
052526-001	Direct Response Installation Manual