

FOR THE MOTORIZED FREEDOM WINDOW & OTD LATERAL ARMS

RV Kits

**Models:** Freedom Window & Over the Door (OtD) awnings and Mariner awnings with the exterior worm drive motor.

**Concern:** This procedure details the steps to remove the motor when the motor fails and the awning is closed and mounted on the vehicle. First time replacements with the replacement motor will require new LH motor covers.

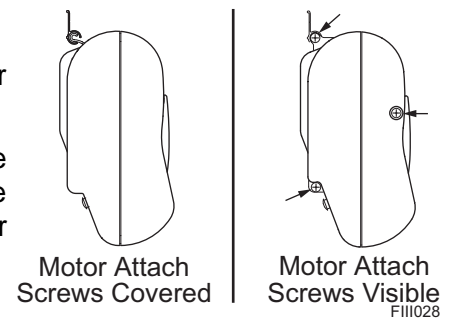

REMOVING THE EXISTING MOTOR (MOTOR ATTACH SCREWS ARE NOT EXPOSED)

1. Disconnect the motor wires:
  - If possible, inside the unit, locate the motor wires where they route through the wall and tie into the coach harness. Mark the wire colors then disconnect or cut the wires from the motor.
  - If the wires are not accessible on the inside, see note in step 4.
2. Use a 3/4" drill or hole saw and make 4 holes into the LH end cap as shown on the right. Hole positions do not have to be exact. The hole in the top of the case should line up with the upper attach screw and cut away the inner wall of the end cap screw channel.
3. Remove the 3 screws that hold the motor assembly to the case.

**CAUTION**

**DURING THE NEXT STEPS, IT IS IMPORTANT THAT A SECOND PERSON HOLDS THE LEADING EDGE IN. WHEN THE MOTOR AND ROLL BAR ARE SEPARATED, THE SPRING ARMS WILL EXTEND RAPIDLY IF NOT HELD. THIS CAN CAUSE PERSONAL INJURY AND PROPERTY DAMAGE.**

4. With a second person holding the lead rail, pull the motor assembly and end caps from the awning. DO NOT allow the roll bar to disengage from the RH end plate.

**NOTES:**

- If the wires are not disconnected in step 1, carefully pull the motor and caps until the wires are exposed. Tape or clamp wires to prevent them from falling back into the wall then cut the wires from the cap.
  - The motor will be difficult to pull from the case. It may be necessary to use a large screwdriver to pry the motor from the case. Use care to not damage the case or case paint.
5. While supporting the LH end of the roll bar, slowly allow the lead rail to extend 8"-10" then press the lead rail in 2"-3". Using a minimum 1/4" rope, firmly tie the center elbows of the spring arms together, do not use bungee cords. This will release the fabric tension on the roll bar and keep the lead rail from extending. (Refer to Figure 2 – Securing the Arms.)

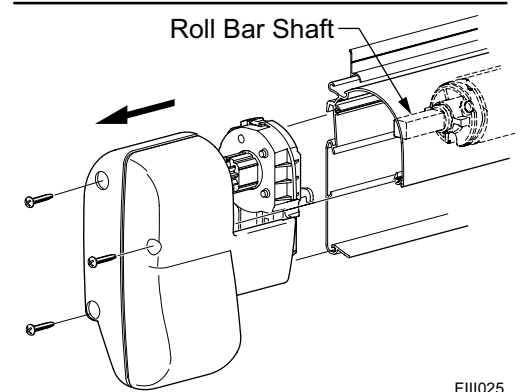
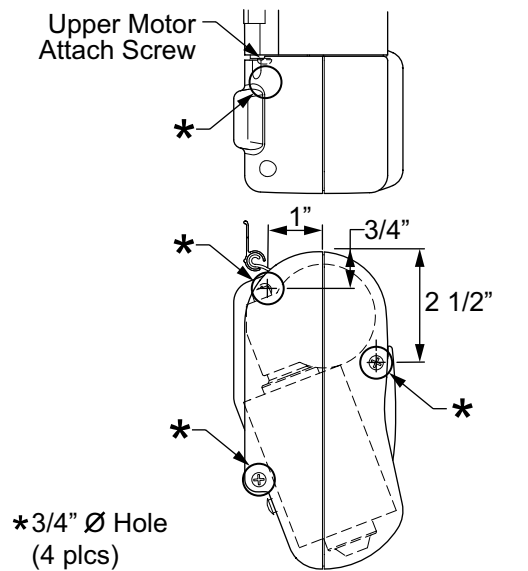

**Figure 1. Motor Removal - Screws Not Exposed.**

## REMOVING THE EXISTING MOTOR (MOTOR ATTACH SCREWS ARE EXPOSED)

TO AVOID POSSIBLE PERSONAL INJURY AND PROPERTY DAMAGE, TWO PEOPLE ARE REQUIRED TO PERFORM PORTIONS OF THIS PROCEDURE.

1. Disconnect the motor wires:
  - If possible, inside the unit, locate the motor wires where they route through the wall and tie into the coach harness. Mark the wire colors then disconnect or cut the wires from the motor.
  - If the wires are not accessible on the inside, see note in step 4.
2. Remove the 3 screws that hold the motor assembly to the case.

### ⚠ CAUTION

**DURING THE NEXT STEPS, IT IS IMPORTANT THAT A SECOND PERSON HOLDS THE LEADING EDGE IN. WHEN THE MOTOR AND ROLL BAR ARE SEPARATED, THE SPRING ARMS WILL EXTEND RAPIDLY IF NOT HELD. THIS CAN CAUSE PERSONAL INJURY AND PROPERTY DAMAGE.**

3. With a second person holding the lead rail, pull the motor assembly and end caps from the awning. DO NOT allow the roll bar to disengage from the RH end plate.

**NOTE: If the wires are not disconnected in step 1, carefully pull the motor and caps until the wires are exposed. Tape or clamp wires to prevent them from falling back into the wall then cut the wires from the end cap.**

4. While supporting the LH end of the roll bar, slowly allow the lead rail to extend 8"-10" then press the lead rail in 2"-3". Using a minimum 1/4" rope, firmly tie the center elbows of the spring arms together, do not use bungee cords. This will release the fabric tension on the roll bar and keep the lead rail from extending.

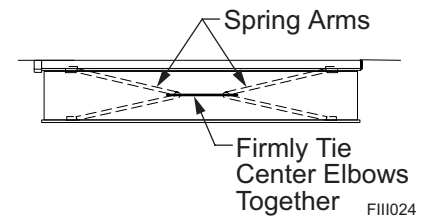

Figure 2. Securing the Arms.

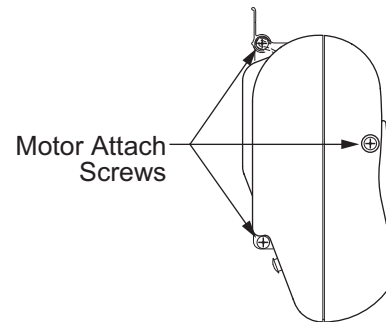
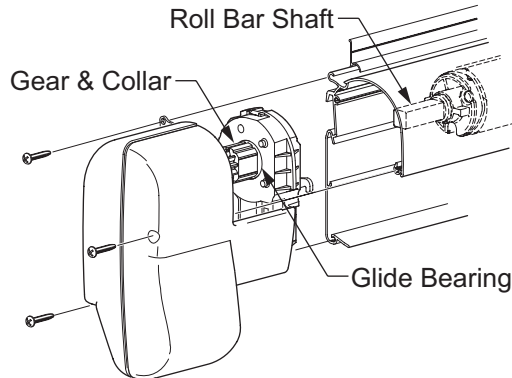

Figure 3. Motor Removal - Screws Exposed.

## INSTALLING THE NEW MOTOR

**NOTE:** All replacement motor plate and end caps have been configured to allow access to the motor attaching screws from outside of the end cap.

1. Bench test the new motor before proceeding. To test, touch the motor leads to a power source such as a drill motor battery.
2. On the bench, attach the motor wire jumpers to the new motor assembly and to the rear half of the end cap.
3. Attach the end cap halves on the motor. The end cap can only fit one way over the motor. Secure the end cap halves with the 3 screws provided.

**NOTE:** Previous covers used 4 screws.

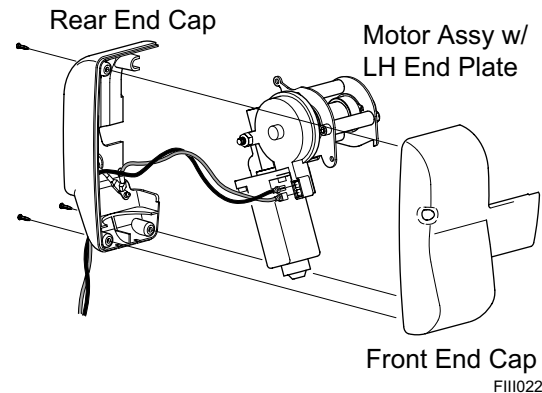

Figure 4. Preparing the Replacement Motor.

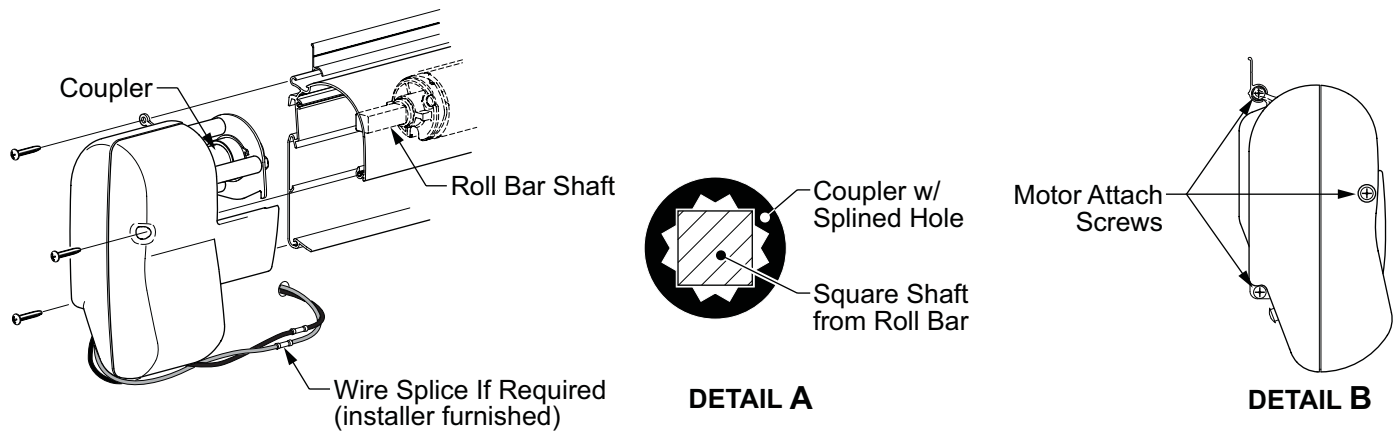

Figure 5. Installing the Replacement Motor.

4. Insert the LH end plate into the case.
5. *If the external motor wires were removed from inside the coach:* Insert the new wires through the access hole.
6. *If the motor wires were cut on the outside of the coach:* Trim excess wire from the end cap and splice the new and old wires together. Feed the splices and wires through the access hole.
7. Push the motor assembly into the case. At the roll bar, align the roll bar's square shaft with the motor coupler. Continue pushing until the motor plate of the assembly is flush against the awning case.

**NOTE:** (Detail A) the new coupler is splined to simplify aligning the square shaft in the coupler.

8. Attach the motor assembly to the case with the screws removed previously.
9. If the external motor wires were disconnected from inside the vehicle, connect the new wires where the old wires were removed.
10. Carefully remove the cord used to tie the spring arms together.
11. Test the awning operation. If the awning operates opposite the switch markings, reverse the red and black motor wires on the back of the switch.