



WIND SMART AUTO-RETRACT SYSTEM

INSTALLATION & OPERATIONS MANUAL

RV

THIS PUBLICATION COVERS THE FOLLOWING OPTIONAL EQUIPMENT KITS:

SR0023, SR0032 - Wind Smart Upgrade - Eclipse

SR0013 Wind Smart Upgrade – One Touch

SR0014 – Remote Control Upgrade – Wind Smart

TABLE OF CONTENTS

Introduction ..... 2
Product Overview ..... 2
Safety Information..... 2
Safety Notes ..... 2
Installation ..... 3
Components Checklist..... 3
Prior to Installing the Kit..... 4
Installing the Switches ..... 5
Wiring an Additional Patio Switch..... 6
Installing the Wind Smart Control Box ..... 6
Installing the Anemometer ..... 7
Testing the System ..... 8
Testing Standard Operation..... 8
Testing Wind Smart Operation ..... 9
Installing the RR24 RF Remote Receiver ..... 10
Programming the RR24 for the Key FOB ..... 11
Testing the Key FOB ..... 11
Diagnostics ..... 12
System Schematic..... 16
Operating the Wind Smart System ..... 17
The Basics ..... 17
Mode Switch ..... 17
Patio Switch..... 17
The Wind Smart Auto-Retract System..... 17
Sensitivity Switch..... 17
Using the Key FOB Remote Control..... 18
Limited Warranty ..... 19

## INTRODUCTION

### PRODUCT OVERVIEW

The Wind Smart Auto-Retract System may be installed as part of the original motorized awning installation or as an upgrade to an existing motorized awning installation. In addition, an optional RF wireless remote may be included at time of installation or added after the installation.

The system offers three unique features not available with a standard awning installation.

- 1) **Auto-Retract** – When the awning is retracted, it retracts completely. It is not necessary to hold the button when closing the awning.
- 2) **Wind Smart** – The awning can be set to automatically close when windy conditions occur.
- 3) **Remote Control** – The operator can conveniently operate the awning from any location.

### SAFETY INFORMATION

#### WARNING

A WARNING INDICATES A POTENTIALLY HAZARDOUS SITUATION WHICH , IF NOT AVOIDED, COULD RESULT IN DEATH OR SERIOUS INJURY AND/OR MAJOR PROPERTY DAMAGE.

#### CAUTION

A CAUTION INDICATES A POTENTIALLY HAZARDOUS SITUATION THAT MAY CAUSE MINOR TO MODERATE PERSONAL INJURY AND/OR PROPERTY DAMAGE. IT MAY ALSO BE USED TO ALERT AGAINST UNSAFE PRACTICES.

**NOTE:** A note indicates further information about a product, part, or step.

*Tip:* A tip provides helpful suggestions.

#### *Safety Notes*

- Always disconnect battery or power source before working on or around the electrical system.
- Always wear appropriate safety equipment (i.e. goggles).
- Always use appropriate lifting devices and/or helpers when lifting or holding heavy objects.

# INSTALLATION

## COMPONENTS CHECKLIST

### Wind Smart Kit

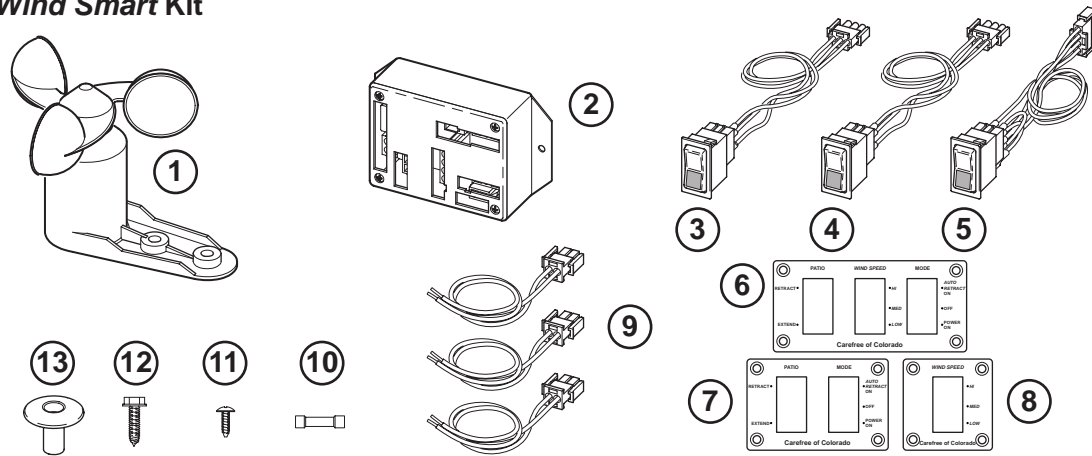

### Remote Control Kit (ordered separately)

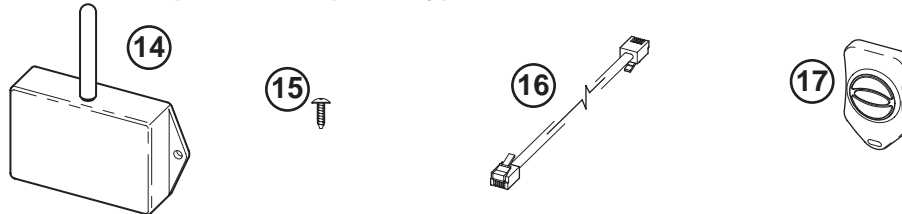

WS001

Figure 1. Component Checklist.

<input checked="" type="checkbox"/>	ITEM	DESCRIPTION	QTY	NOTE
<b>WIND SMART KIT</b>				
<input type="checkbox"/>	1	Anemometer	1	
<input type="checkbox"/>	2	RP24 Control Unit	1	
<input type="checkbox"/>	3	Switch, Patio, Momentary Contact	1	
<input type="checkbox"/>	4	Switch, Wind Speed, Latching, w/o Light	1	
<input type="checkbox"/>	5	Switch, Mode, Latching, w/ Light	1	
<input type="checkbox"/>	6	Switch Plate, 3 Switch	1	
<input type="checkbox"/>	7	Switch Plate, Patio/Mode	1	
<input type="checkbox"/>	8	Switch Plate, Wind Speed	1	
<input type="checkbox"/>	9	Harness, Power, Motor, Anemometer	3	
<input type="checkbox"/>	10	Wire Splice, 14-16GA.	6	
<input type="checkbox"/>	11	Screw, Phillips Truss Head	#6 x 1/2	10
<input type="checkbox"/>	12	Screw, Hex Head	#10 x 3/4	2
<input type="checkbox"/>	13	Grommet, Wall		1
<b>REMOTE CONTROL KIT</b>				
<b>ORDERED SEPARATELY</b>				
<input type="checkbox"/>	14	RR24 Receiver, RF	1	
<input type="checkbox"/>	15	Screw, Phillips Truss Head	#6 x 1/2	2
<input type="checkbox"/>	16	Cable 60"	1	
<input type="checkbox"/>	17	Remote Control Key Fob	1	1

**NOTES:**

- Additional remote control Key FOBs may be ordered separately.

## PRIOR TO INSTALLING THE KIT

*For New Installations* – These instructions assume that the awning and arms have been mounted and that the cable(s) from the arms have been routed through the exterior wall as described in the awning installation instructions. These instructions replace the switch and wiring directions included with the awning.

*For Existing Installations* – The installer must locate and remove any existing control boxes and switches (not including the exterior switch with the Eclipse). Access to the motor cable(s) and the 12VDC/Ground wires is required.

There are three (3) switch plate configurations available for this installation.

- A) Three switch plate (this should be used unless the plate does not fit in the desired location).
  - B) Two switch plate plus a single switch plate (this option is used when it is necessary to “stack” the switches because of space limitations)
  - C) Two switch plate (this is used because of space restrictions). This configuration eliminates the “Wind Speed Switch”. When the wind speed switch is not used, the system defaults to the “medium” setting.
1. Determine the location of the switches and control box:
    - 1.1 Do not mount the control box and switches near heat producing elements such as LP appliances or engine exhaust components.
    - 1.2 The mounting surface for the switch plate should be a minimum of 1/2” thick.
    - 1.3 The clearance dimensions for the switch plates are shown in Figure 2 on page 5.
    - 1.4 Mount the control box near the switch panel so that the switch harnesses can be plugged into the control box without stressing the connections. Clearance dimensions are shown in Figure 3 on page 6.
  2. Determine the location of the anemometer:
    - 2.1 Position the anemometer in a location that is not blocked from the wind. Suitable positions would be along the roofline or on the roof.
    - 2.2 Approximately 6 foot of cable is furnished with the anemometer. It is the installer’s responsibility to provide additional cable and splices if the anemometer is mounted a greater distance from the control box.
    - 2.3 For the Eclipse and One-Touch, the anemometer cannot be mounted on the case of the awning.
  3. Determine the location of the optional RF receiver (RR24):
    - 3.1 Do not mount the RR24 unit near heat producing elements such as LP appliances or engine exhaust components.
    - 3.2 For best reception, do not mount the RR24 near or on a metal surface.
    - 3.3 Mount the unit with the antenna pointing up.
    - 3.4 The clearance dimensions for the RR24 are shown in Figure 6 on page 10.
    - 3.5 The included cable is approximately 60 inches long. Mount the unit close enough to the control box so that the cord can be connected without stressing the connections.

### CAUTION

**ALWAYS DISCONNECT THE VEHICLE BATTERY AND ELECTRICAL SOURCES BEFORE WORKING WITH THE ELECTRICAL WIRING AND COMPONENTS.**

When the *WindSmart* installation is complete, return to the original awning instructions for any final assembly required.

## INSTALLING THE SWITCHES

(refer to Figure 2)

1. At the switch panel location(s), use a 2 1/4" hole saw and cut one hole for each switch. The center of each hole is 1 1/2" apart for switches mounted in the same panel.
2. Each switch assembly is labeled. Carefully push the connector and wires through the switch panel then push the switch into the faceplate until the locking tabs click into place behind the faceplate.
  - The momentary switch is the "Patio" switch;
  - The latching switch w/o light is the "Wind Speed" switch;
  - The latching switch w/ light is the "Mode" switch.

### ⚠ CAUTION

**ENSURE THAT THE SWITCH LABELS MATCH THE FACEPLATE LABELS FOR THE SWITCH IDENTIFICATION AND ORIENTATION! THE SQUARE LENS ON THE SWITCH MUST BE AT THE BOTTOM.**

**NOTE: If it is necessary to remove the switch from the panel, press and hold the locking tabs on the switch then carefully work the switch out of the panel. Do not try to force the switch, it is possible to break the locking tabs.**

3. After all switches are mounted into the faceplate(s), carefully push the connectors, wires and switches into the mounting holes drilled in step 1.
4. Hold the faceplate(s) in position and secure to the mounting surface using four (4) #6 x 1/2 screws.

*Tip: Drilling a small pilot hole for the screws will reduce the chance of splitting or stripping out the hole with the screws.*

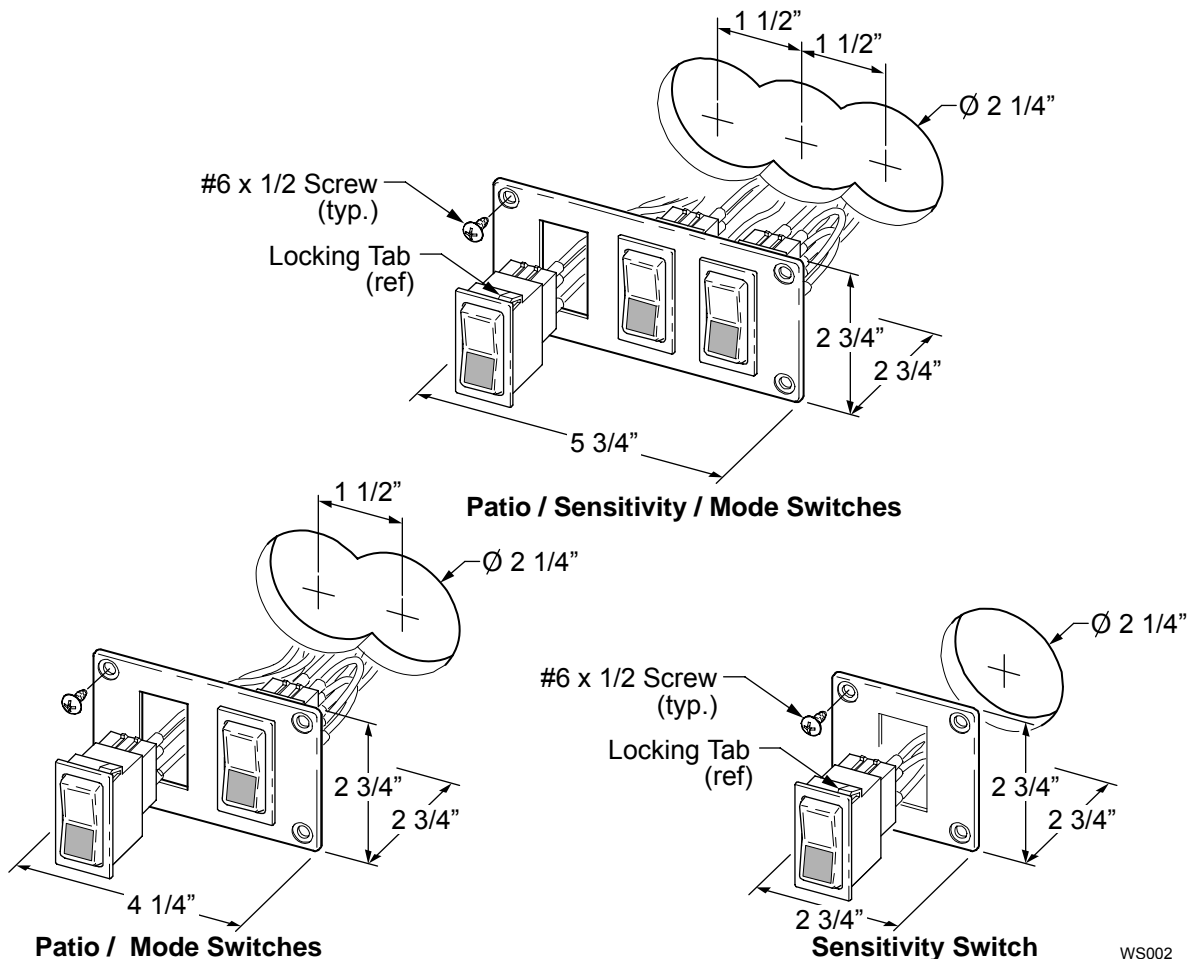

WS002

Figure 2. Mounting the Switches.

### Wiring an Additional Patio Switch

This section is for wiring an additional PATIO switch and for Eclipse models with an exterior switch.

(refer to the schematic on page 16)

1. Route the switch wires to the main switch location.
2. Splice the wires in parallel with the main PATIO switch wires. Pin 1 of the additional switch should go to pin 1 of the main patio switch etc.

### INSTALLING THE WIND SMART CONTROL BOX

1. Position the control box and secure using two (2) #6 x 1/2" screws.

**NOTE: If the box is mounted on a surface that is less than 1/2" thick, the screws will protrude through the opposite side of the surface.**

2. Attach the switch harness connectors to the box at the positions labeled on the box. Press the connectors in until the tabs click into place to ensure a solid connection.
3. Run a 12 gauge wire (never use less than 14 gauge) from the power distribution panel (auxiliary battery circuit) or equivalent.
4. Run a wire to chassis ground. Suitable ground would be the vehicle chassis or conductive structure connected to the chassis.
5. Connect a two-wire harness to the control box in the position marked +12V/GROUND.
6. Splice the wires from steps 2 and 3 to the harness. Carefully note the labeling on the box so that the 12V power goes to the 12V pin and the ground goes to the pin labeled ground.
7. Connect a two-wire harness to the control box in the position marked MOTOR.
8. Run the motor wire cable from the awning to the control box. Splice the wires to the harness in step 7. The red wire should go to Pin marked "A" and the black goes to the pin marked "B".

**NOTE: During testing, it may be necessary to reverse these wires (red to B, black to A) if the awning extend and retract functions are reversed.**

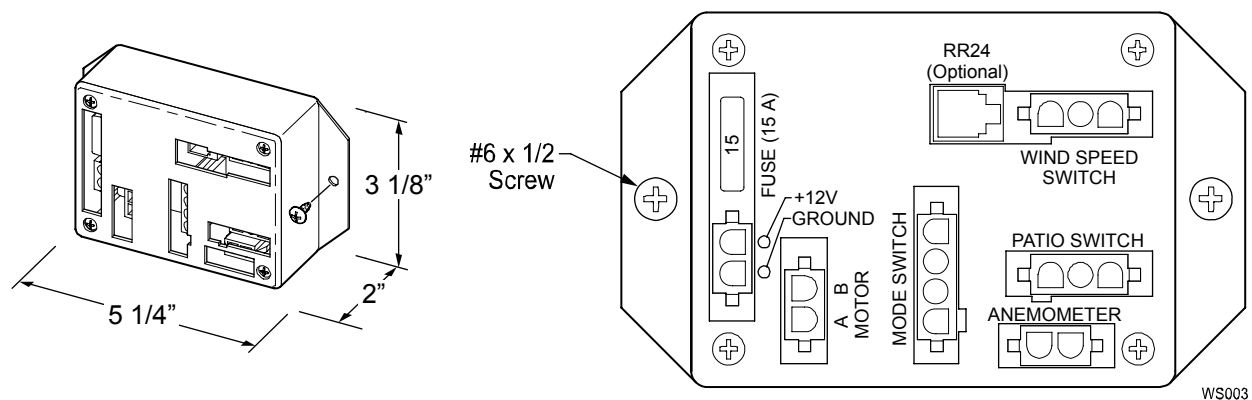

Figure 3. Mounting the Wind Smart Control Box.

## INSTALLING THE ANEMOMETER

**NOTE:** Whenever drilling and mounting on the outside wall or roof, be aware of internal cabinet framing or other structure that may be behind the outer surface. Adjust drill locations as necessary to prevent unnecessary damage. Interior structure and components could also interfere with drilling and cable routing.

(refer to Figure 4)

1. Position the anemometer in location and mount using two (2) #10 x 3/4 screws.
  - Align the screw holes with a roof support;
  - For rubber roofs, do not drill pilot holes for the mounting screws;
  - For fiberglass roofs, drill two pilot holes using the anemometer as a template.
  - Coat the bottom of the anemometer with silicone sealant. With particular attention around the mounting holes.
2. Drill a 7/16" hole in the sidewall or roof, close to the anemometer.
3. Slide the cable through the grommet and into the hole drilled in step 2.
4. Coat the underside of the grommet flange with a silicone sealant; then seat the grommet in the hole.
5. Push the wire through the grommet for best fit then seal the wire in the grommet with silicone sealant.

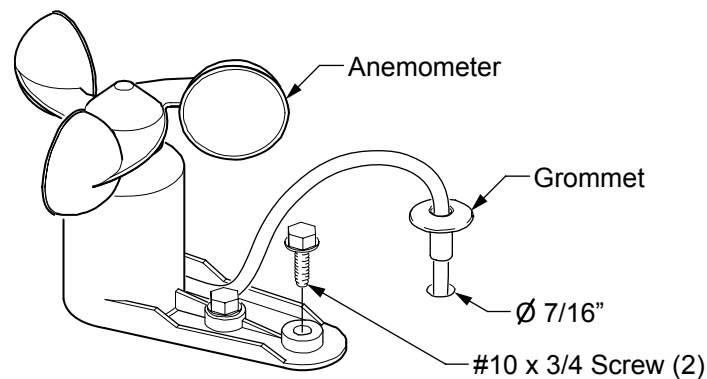

**Figure 4. Mounting the Anemometer.**

6. Route the cable to the control box.
7. (refer to Figure 3) Connect the last two-wire harness to the control box in the position marked ANEMOMETER.
8. Splice the two wires from the anemometer to the harness. The wires are not pin specific.
9. Go to Testing the System on page 8 before installing the RF remote option.

## TESTING THE SYSTEM

Ensure that the operator can see the awning during the tests or has a helper that can see the awning.

Definitions: *Manual* – the motor runs only while the switch is pressed.

*Automatic* – the motor continues to run after the button is released.

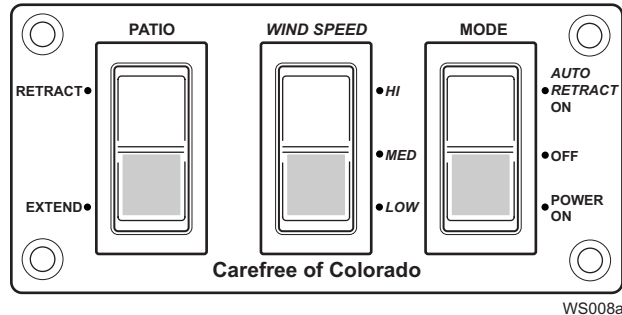

Figure 5. Control Switches.

## TESTING STANDARD OPERATION

### ⚠ CAUTION

THE RETRACT FUNCTION IS AUTOMATIC AND WILL CONTINUE UNTIL THE AWNING IS FULLY RETRACTED. ENSURE THAT DURING TESTING AND OPERATION, NO OBSTACLES OR PEOPLE ARE IN THE WAY OF THE AWNING.

**NOTE:** For the Eclipse, the extend function is automatic. For One-Touch, the extend function is manual. For testing the One-Touch, the operator must press and HOLD the extend switch.

1. Turn the MODE switch to the OFF position and restore vehicle power.
2. Press and release the PATIO switch in the EXTEND position. The awning should not move.
3. Press and release the PATIO switch in the RETRACT position. The awning should not move.
4. Turn the Mode switch to the POWER ON position.
5. Press and release the PATIO switch in the EXTEND position. The awning should extend automatically. Allow the awning to extend for 2-3 seconds then press and release the PATIO switch a second time to stop the awning.

**STOP:** If the awning does not move or functions differently than described above, set the Mode switch to the off position. Go to the Diagnostics section on page 12. Restart the tests after following the steps in the Troubleshooting section.

6. Press and release the PATIO switch in the RETRACT position. The awning should retract automatically. Allow the awning to retract for 2-3 seconds then press and release the PATIO switch a second time to stop the awning.

**STOP:** If the awning does not move or functions differently than described above, set the Mode switch to the off position. Go to the Diagnostics section on page 12. Restart the tests after following the steps in the Troubleshooting section.

7. Press and release the PATIO switch in the RETRACT position. The awning should retract automatically until it is completely closed. The motor should stop when the awning is fully retracted.
8. Carefully secure the anemometer so that the cups cannot spin during the next tests.
9. Turn the Mode switch to the WIND SMART ON position.
10. Repeat steps 5 through 7.



## TESTING WIND SMART OPERATION

**NOTE:** These tests will use the WIND SPEED switch.

**HI** is the least sensitive and responds to winds approximately equal to 12 mph.

**MEDIUM** responds to winds approximately equal to 8mph.

**Low** is the most sensitive and responds to winds approximately equal to 4mph.

1. If not previously done, release the anemometer (step 7 above).
2. Set the MODE switch to WIND SMART ON.
3. Set the WIND SPEED switch to HI.
4. Extend the awning using the PATIO switch.
5. Spin the anemometer. The awning should retract automatically to the closed position.

**NOTE:** Do not hit the anemometer to spin. Using compressed air provides a constant pressure source and, the output can be regulated to test the various sensitivity settings. DO NOT position the nozzle closer than 10 inches from the cups.

**STOP:** If the awning does not move or functions differently than described above, set the Mode switch to the off position. Go to the Diagnostics section on page 12. Restart the tests after following the steps in the Troubleshooting section.

6. Repeat steps 3 and 4 two (2) more times with the Wind Speed switch set to MED and then to LOW.
7. Repeat steps 2 through 4 with the Mode switch set to OFF and POWER ON. The awning should not move.

# INSTALLING THE RR24 RF REMOTE RECEIVER

1. Determine the location of the optional RF receiver (RR24):
  - 1.1 Do not mount the RR24 unit near heat producing elements such as LP appliances or engine exhaust components.
  - 1.2 For best reception, do not mount the RR24 near or on a metal surface.
  - 1.3 Mount the unit with the antenna pointing up.
  - 1.4 The clearance dimensions for the RR24 are shown in Figure 6 on page 10
  - 1.5 The included cable is approximately 60 inches long. Mount the unit close enough to the control box so that the cord can be connected without stressing the connections.
  - 1.6 Allow adequate room below the box to access the connector jack, programming button and indicator light.
2. Position the control box and secure using two (2) #6 x 1/2" screws.
 

**NOTE: If the box is mounted on a surface that is less than 1/2" thick, the screws will protrude through the opposite side of the surface.**
3. Connect the cable to the RR24.
4. Route the cable to the Wind Smart control box and connect.

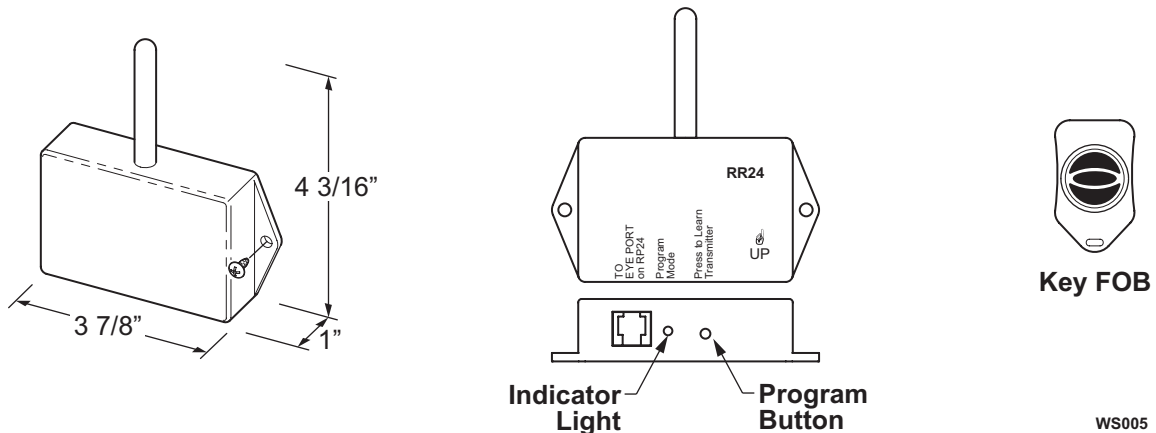

**Figure 6. Mounting the RF Receiver.**

WS005

## PROGRAMMING THE RR24 FOR THE KEY FOB

1. Power to the Wind Smart control box must be on.
2. Press and release the “Press to Learn Transmitter” button on the bottom of the RR24 box. The receiver is in program mode when the red light comes on.
3. Press and release the CENTER button on the Key FOB. The red light will go out after the RR24 learns the Key FOB signal.
4. Repeat steps 2 and 3 for each additional Key FOB.

### OPERATIONAL NOTES:

- The RR24 exits the program mode after ten seconds.
- If the light does not come on in step 2, check the continuity of the cord between the boxes and repair or replace as required. Pin 1 of the 1<sup>st</sup> connector goes to pin 1 of the 2<sup>nd</sup> connector etc. If the light still does not come on, the memory is full and must be cleared.
- If the light does not go out in step 3, the RR24 knows the Key FOB signal or the battery in the FOB needs to be replaced.
- To clear the RR24 memory, press and hold the program button for 5 seconds.
- The RR24 may be programmed for up to 5 Key FOBs. Additional Key FOBs may be ordered separately.

## TESTING THE KEY FOB

Prior to testing the remote control Key FOB, the Wind Smart system must be fully installed, tested and operational. If the system has not been tested, go to “Testing the System” on page 8 before continuing this section.

1. Ensure that power is on to the Wind Smart control box.
2. Extend the awning out about half way.
3. Set the MODE switch to “OFF”.
4. Press each button on the Key FOB. The awning should not move.
5. Set the MODE switch to “POWER ON”.
6. Press and hold the EXTEND button on the Key FOB for 2 to 3 seconds; then release the button. The awning should extend out until the button is released

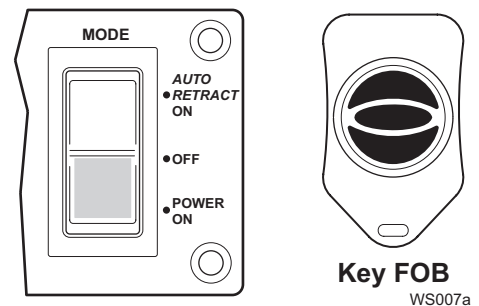

Figure 7. Key FOB Test.

7. Press and release the RETRACT button on the Key FOB. The awning should retract automatically.

### ⚠ CAUTION

**THE RETRACT FUNCTION IS AUTOMATIC AND WILL CONTINUE UNTIL THE AWNING IS FULLY RETRACTED. ENSURE THAT DURING TESTING AND OPERATION, NO OBSTACLES OR PEOPLE ARE IN THE WAY OF THE AWNING.**

8. While the awning is retracting, press and release the STOP (center) button on the Key FOB. The awning should stop when the button is pushed.

**NOTE: The retract function will also stop if the extend or retract buttons are pushed once.**

9. Set the MODE switch to “WIND SMART ON”.
10. Repeat steps 6 through 9.
11. If the Key FOB does not operate as described previously, use diagnostics “D08 Awning Does Not Move When Key FOB Buttons Are Pushed” on page 15.

# DIAGNOSTICS

The following procedures are intended to aid the installer and service technician to logically resolve operational issues with the Wind Smart installation. These procedures do not address conditions that may arise with the basic awning installation. For awning related concerns, refer to the appropriate awning manual.

<b>Procedures in this section:</b>	<b>Page</b>
<b>D01 THE AWNING DOES NOT EXTEND AND/OR RETRACT USING THE PATIO SWITCH.....</b>	<b>12</b>
<b>D02 THE AWNING OPERATES IN REVERSE OF THE SWITCH PLATE LABEL .....</b>	<b>12</b>
<b>D03 THE AWNING AUTO-EXTENDS WHEN THE RETRACT SWITCH PUSHED .....</b>	<b>12</b>
<b>D04 THE AWNING AUTO-EXTENDS AND MANUALLY RETRACTS .....</b>	<b>12</b>
<b>D05 AWNING DOES NOT AUTO-RETRACT DURING WINDY CONDITIONS .....</b>	<b>13</b>
<b>D06 TESTING A SWITCH AND HARNESS.....</b>	<b>13</b>
<b>D07 TESTING THE CONTROL BOX .....</b>	<b>14</b>
<b>D08 AWNING DOES NOT MOVE WHEN KEY FOB BUTTONS ARE PUSHED.....</b>	<b>15</b>

*In the charts below, YES is a positive response to the test; NO is a negative response.*

<b>D01 THE AWNING DOES NOT EXTEND AND/OR RETRACT USING THE PATIO SWITCH</b>			
<i>The Mode switch must be in the POWER ON or WIND SMART ON positions.</i>			
<b>A</b>	Confirm Power Supply	YES	Go to test B
	Is vehicle battery or power source providing 10V to 14V to the control box.	NO	Correct as required
<b>B</b>	Confirm Operation of MODE Switch	YES	Switch and harness OK; go to test C
	Use test procedure "D06 Testing a Switch and Harness"	NO	Repair or replace as recommended in procedure and retest
<b>C</b>	Confirm Operation of PATIO Switch	YES	Switch and harness OK; go to test D
	Use test procedure "D06 Testing a Switch and Harness"	NO	Repair or replace as recommended in procedure and retest
<b>D</b>	Is the control box operating correctly?	YES	Control box OK; refer to awning's troubleshooting guide
	Use procedure "D07 Testing the Control Box"	NO	Repair as recommended in procedure and retest
<b>D02 The Awning Operates In Reverse of the Switch Plate Labeling</b>			
<i>The Mode switch must be in the POWER ON or WIND SMART ON positions.</i>			
<b>A</b>	Confirm Operation of PATIO Switch	YES	Switch and Harness OK; go to test B
	Use test procedure "D06 Testing a Switch and Harness"	NO	Repair or replace as recommended in procedure and retest
<b>B</b>	Is the control box operating correctly?	YES	Power and Control Box OK
	Use test procedure "D07 Testing the Control Box"	NO	Repair as recommended in procedure and retest
<b>D03 THE AWNING AUTO-EXTENDS WHEN THE RETRACT SWITCH PUSHED</b>			
<i>The Mode switch must be in the POWER ON or WIND SMART ON positions.</i>			
<b>A</b>	Reverse motor leads at control box and retest	YES	Test OK
		NO	Reanalyze condition
<b>D04 The Awning Auto-Extends and Manually Retracts</b>			
<i>The Mode switch must be in the POWER ON or WIND SMART ON positions.</i>			
	1. Reverse motor leads at control box	YES	Test OK
	2. Check that switch is oriented correctly in plate – correct as required (refer to D06-A and D06-B)	NO	Reanalyze condition

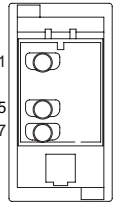
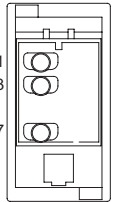
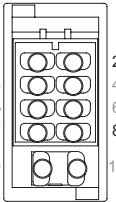
<b>D05 AWNING DOES NOT AUTO-RETRACT DURING WINDY CONDITIONS</b>				
<i>NOTE: The mode switch must be set to "Wind Smart ON"</i>				
<b>A</b>	Confirm that the retract function works using the PATIO switch	YES	Function works using the switch; go to test B	
		NO	Function does not work with switch; go to procedure D01 on page 12	
<b>B</b>	Test Anemometer			
	1	Do the anemometer cups spin freely?	YES Go to step B2 NO Anemometer defective - replace	
	2	Test signal from anemometer: 2.1 Remove anemometer connector from control box; 2.2 Place continuity tester between pins of connector; 2.3 Have a helper slowly turn the anemometer: Does the circuit open and close? It should open and close once for every revolution.	YES	Plug the connector into the control box; Go to "Testing The Control Box"
			NO	The circuit stays open or stays closed; go to step B3
	3	Test the wire continuity between the connector and the anemometer.	YES	Continuity OK; replace anemometer
NO			Repair or Replace wires as required	
<b>D06 TESTING A SWITCH AND HARNESS</b>				
<i>Disconnect the switch harness connectors from the control box and remove the plate and switches from the mounting surface.</i>				
<b>A</b>	Confirm Switch is mounted in correct position and correctly oriented. Refer to Figure 5 on page 8. The lens or lens caps should be on the bottom of the switch as indicated by the shaded area.	YES	Switch mounted OK; go to test B	
		NO	Carefully remove the switch, rotate 180 and reinstall in panel. Reconnect harnesses and retest	
<b>B</b>	Confirm switch is wired correctly. Use the schematic and confirm the wires from the switch to the connector are correctly placed.	YES	Switch wired OK; go to test C	
		NO	Rewire the switch according to the schematic on page 16	
<b>C</b>	Test the Switch Function (this test requires a continuity tester)			
	<ul style="list-style-type: none"> <li>Do not remove the wires from the back of the switch. From the numbered terminal of the switch, trace the wire to the connector; place the tester leads on the connector pins. The pins are not marked on the connector.</li> <li>Steps 1 through 5 are for the Patio and Wind Speed Switches. Refer to step 6 for the Mode Switch.</li> </ul>			
	1	Using a continuity tester, place one lead on common (Pin 3 – Patio; pin 5 – Wind Speed). Place the second lead on pin 1. Put the switch in the center position and measure the continuity. Move the second lead to pin 7, measure the continuity. Circuit should be open	YES	Circuits are open, go to step 2.
			NO	Circuit(s) are closed (continuity exists); switch assy is defective - replace
	2	Place the second lead on pin 1. Press the switch down ("Extend" for patio, "Lo" for sensitivity). Is circuit closed?	YES	Circuit closed; go to step 3
			NO	Circuit open; switch defective-replace
	3	Leave the leads in position of step 2. Press the switch up ("Retract" for patio, "Hi" for sensitivity). Is the circuit open?	YES	Circuit open; go to step 4
			NO	Circuit closed, switch defective-replace
4	Move the second lead to pin 7. Press the switch down ("Extend" for patio, "Lo" for sensitivity). Is the circuit open?	YES	Circuit open; go to step 5	
		NO	Circuit closed, switch defective-replace	
5	Leave the leads in position of step 4. Press the switch up ("Retract" for patio, "Hi" for sensitivity). Is the circuit closed?	YES	Circuit closed; go to step 6	
		NO	Circuit open; switch defective-replace	
6	For Mode Switch only – Follow steps 1 through 5 using pins 5, 2 and 8 respectively	YES	Switch tests OK, return to diagnostic	
		NO	Test failed; switch defective	
<div style="display: flex; justify-content: space-around; align-items: flex-end;"> <div style="text-align: center;">  <p>Wind Speed</p> </div> <div style="text-align: center;">  <p>Patio</p> </div> <div style="text-align: center;">  <p>Mode</p> </div> </div> <p style="text-align: right; margin-right: 50px;">WS009a</p>				

<b>D07 TESTING THE CONTROL BOX</b>			
<i>This test has been developed as a bench test of the control box.</i>			
<b>A</b>	<b>Test Power</b>		
	1 Check Fuse	YES	Fuse OK; go to step A2
		NO	Replace fuse. If the fuse continues to blow, this may be an indication of a situation with the power lines to the control box or with the control box. If so, replace fuse and go to step A2
	2 Confirm power to the control box: 2.1 Remove connector to control box 2.2 Test voltage across terminals. Value should be between 10V and 14V. Polarity must match symbols on control box.	YES	Voltage and Polarity is correct; go to test B
		YES	Voltage is correct but polarity is reversed. Reverse wires and retest.
NO		Voltage is less than 10V. Check vehicle power sources and correct as required. If battery is OK, check wire continuity to power plug and repair as required	
<b>B</b>	<b>Test Control Box Function</b>		
	<i>For these tests:</i>		
	<ul style="list-style-type: none"> <li>• Refer to the schematic on page 16:</li> <li>• Remove all plugs from the control box except for the power connector.</li> <li>• Place the positive lead of a voltmeter on pin B (motor) and the negative lead of voltmeter on pin A..</li> </ul>		
	1 Measure the "Power On" Setting 1.1 Place a jumper between pins 6 and 8 (this will simulate "Power On"). 1.2 Place a second jumper between pins 11 and 12 (this will simulate the "Retract Function") 1.3 Does voltage equal -10V to -14V? 1.4 Move the second jumper between pins 12 and 13 this will simulate the "Extend Function" 1.5 Does voltage equal +10V to +14V?	YES	Voltage OK; go to step B1.4
		NO	Control box is defective - replace
		YES	Voltage OK; go to step B2
		NO	Control box is defective - replace
		NO	Control box is defective - replace
	2 Measure the "Wind Smart On" Setting 2.1 Place a jumper between pins 7 and 8 (this will simulate "Wind Smart On"). 2.2 Place a second jumper between pins 11 and 12 (this will simulate the "Retract Function") 2.3 Does voltage equal -10V to -14V? 2.4 Move the second jumper between pins 12 and 13 this will simulate the "Extend Function" 2.5 Does voltage equal +10V to +14V?	YES	Voltage OK; go to step B2.4
		NO	Control box is defective - replace
		YES	Voltage OK; return to diagnostic
NO		Control box is defective - replace	
NO		Control box is defective - replace	

<b>D08 Awning Does Not Move When Key FOB Buttons Are Pushed</b>			
<i>Before continuing, ensure that the Wind Smart system is working correctly. Reference the following sections as needed:</i>			
	<i>"Operating the Wind Smart System"</i>		<i>page 17</i>
	<i>"Testing the System"</i>		<i>page 8</i>
	<i>"Diagnostics"</i>		<i>page 12</i>
	1. Confirm power to Wind Smart control box	--	Correct as required
	2. Confirm Mode switch is set to "Power On" or "Wind Smart On"	--	Correct as required
	3. Check the cable between the RR24 and Windsmart control box. As a continuity check, Pin 1 of connector 1 goes to Pin 1 of connector 2; pin 2 goes to pin 2; pin 3 goes to pin 3 and pin 4 goes to pin 4	YES	Cable is OK. Confirm that cable is securely plugged in; go to step 4
		NO	Repair or Replace as required.
	4. Confirm that the RR24 is programmed for the Key FOB	--	Refer to "Programming the RR24 for the Key FOB" on page 11 and retest. If system does not work; go to step 5
	5. Program a second Key FOB and test	YES	2 <sup>nd</sup> Key FOB works. Replace battery in 1 <sup>st</sup> Key FOB and retest, if no response, 1 <sup>st</sup> Key FOB is defective.
		NO	2 <sup>nd</sup> Key FOB does not work; go to step 6
	6. Replace the RR24 Receiver and test	YES	System works OK. 1 <sup>st</sup> receiver is defective
		NO	System does not work. Reinstall 1 <sup>st</sup> receiver; go to step 7
	7. Replace Wind Smart control box	--	

SYSTEM SCHEMATIC

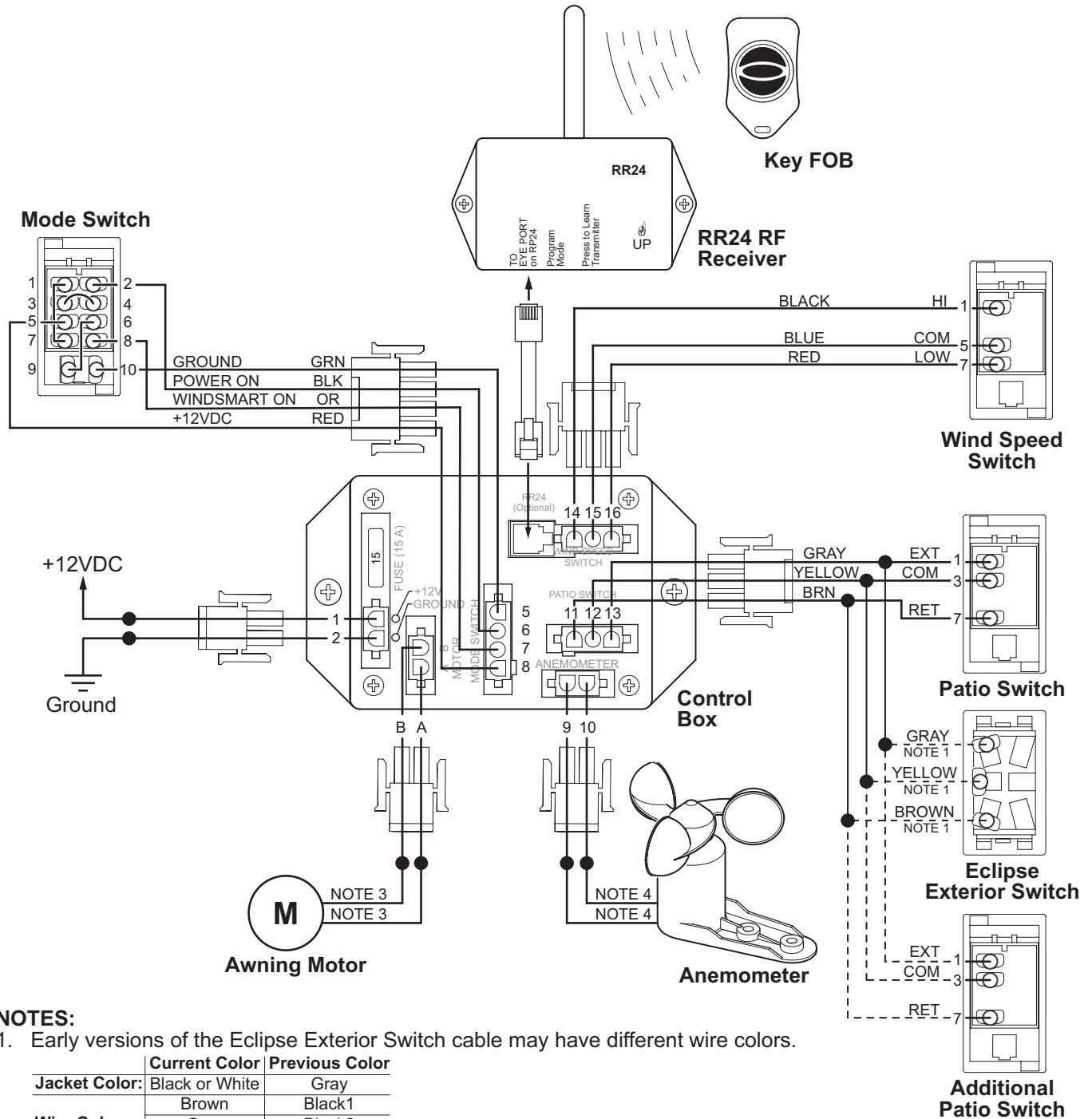

NOTES:

1. Early versions of the Eclipse Exterior Switch cable may have different wire colors.

	Current Color	Previous Color
Jacket Color:	Black or White	Gray
Wire Colors:	Brown	Black1
	Gray	Black2
	Yellow	Yellow/Green

2. Early versions of the Patio Switch harness may have different wire colors.

	Current Color	Previous Color
	Brown	Black
	Gray	Red
	Yellow	Blue

3. Motor wires for the Eclipse: Red - pin B, Black - pin A for the One-Touch: Red - pin A, Black - pin B

4. Wire colors for anemometer are not pin specific.

WS006

Figure 8. System Schematic.



# OPERATING THE WIND SMART SYSTEM

The Wind Smart controls offer a variety of convenient operating options for the motorized awning. During the discourse on controls, the basic 3-switch panel is shown. All switch configurations operate in the same manner; exceptions and additions are noted when applicable.

## THE BASICS

### Mode Switch

This is a 3-position switch.

**OFF** ..... The center position shuts the system down. The awning cannot be extended or retracted in this mode. It is strongly recommended that the switch be in this position whenever the awning is not used and during transport. This will prevent the awning from accidentally extending.

**POWER ON**..... The bottom position activates the switch controls.

**WIND SMART ON**... The top position activates the switch controls and the Wind Smart Auto-Retract system.

When the switch is placed in the **POWER ON** or **WIND SMART ON** position, the switch will illuminate to indicate the system is on.

### Patio Switch

This is a two position momentary contact switch. This description also applies to Eclipse models with an exterior switch or any additional patio switches that may be installed.

**EXTEND**..... *For One-Touch:* Press and hold the switch. The awning extends out until the switch is released.

*For Eclipse:* Press and release the switch. The awning automatically extends until it is fully open. To stop the awning before it is open, press and release the extend switch a second time; or, switch the **MODE** switch to the **OFF** position.

**RETRACT** ..... Press and release the switch. The awning automatically retracts until it is fully closed. To stop the awning before it is closed, press and release the retract switch a second time; or, switch the **MODE** switch to the **OFF** position.

*To operate:* Set the **MODE** switch to **POWER ON** or **WIND SMART ON**.

## THE WIND SMART AUTO-RETRACT SYSTEM

The Wind Smart Auto-Retract System is an exciting enhancement to basic awning operation. When activated, the system will retract the awning automatically in windy conditions.

### Sensitivity Switch

**HI**..... Hi is the least sensitive and responds to winds approximately equal to 12mph.

**MED** ..... Medium responds to winds approximately equal to 8mph.

**LOW** ..... Low is the most sensitive and responds to winds approximately equal to 4mph

**NOTE:** If the sensitivity switch is not installed, the system defaults to the medium setting.

*To operate:* Set the **MODE** switch to **WIND SMART ON** and set the **SENSITIVITY** switch to the desired level.

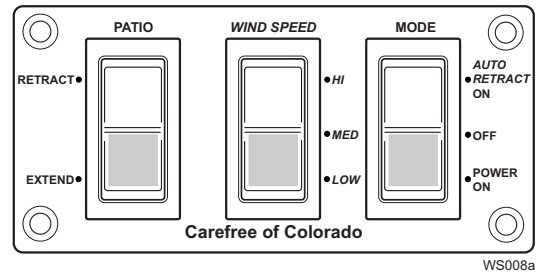

Figure 9. Switch Panel.

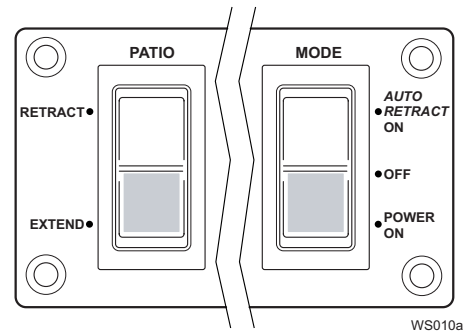

Figure 10. Basic Switch Controls.

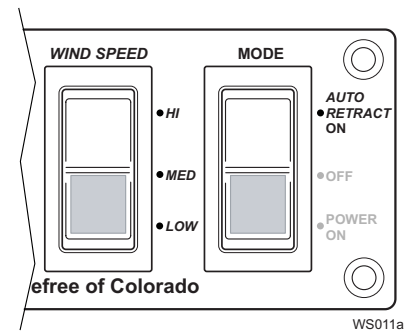

Figure 11. Wind Smart Switches.

### USING THE KEY FOB REMOTE CONTROL

An optional remote control Key FOB is available with the Wind Smart system. In simple terms, the Key FOB is a wireless patio switch and functions in the same manner that the stationary switch does. The Key FOB provides the advantage of allowing the operator to conveniently operate the awning from any location. To use: set the MODE switch to POWER ON or WIND SMART ON.

EXTEND .....*For One-Touch:* Press and hold the switch. The awning extends out until the switch is released.

*For Eclipse:* Press and release the switch. The awning automatically extends until it is fully closed. To stop the awning before it is closed, press and release the extend switch a second time; or, switch the MODE switch to the OFF position.

RETRACT .....Press and release the button. The awning automatically retracts until it is fully closed.

STOP .....The center button is a stop button during the auto-retract.

**NOTE: The retract function will also stop if the extend or retract buttons are pushed once**

The Key FOB has a maximum operating range of 50 feet.

**NOTE: Actual distance may vary depending on the specific installation and location of the receiver in the vehicle.**

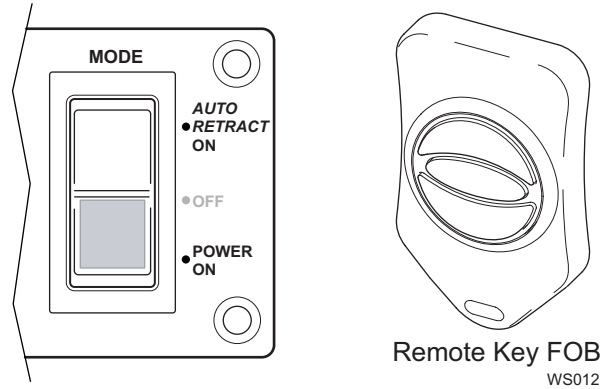

Figure 12. Optional Key FOB.

## LIMITED WARRANTY

Carefree of Colorado (hereafter referred to as Carefree) warrants to the FIRST retail Purchaser that the WindSmart Auto-Retract System is free of defects in material and workmanship within the terms and conditions as set forth below. Carefree's obligation under this warranty is limited to the repair or replacement, at Carefree's option, of any defective component within the stated warranty period. THIS WARRANTY IS NOT TRANSFERABLE.

### 1. DURATION

- a) 12 months on parts, labor and freight on electronic components.

Warranty duration is not extended by the length of time the product is not in use or the time which the purchaser is deprived the use of the product. The duration of coverage is determined by the date of the original product purchase, not the date of repairs.

### 2. WHAT IS COVERED UNDER THIS WARRANTY

Defects in the manufacturer's material and workmanship of product under normal use, and which occur within the duration of the warranty period. The following components are covered only as listed:

- a) *Electronics – Defects.*

### 3. WHAT IS NOT COVERED UNDER THIS WARRANTY

- a) Improper installation and/or any damage or failure that results from improper installation of the product, including fabric damage caused by improper installation.
- b) Normal wear.
- c) Conditions that are not related to the material or workmanship of the product: including any failure that results from an accident, wind, rain, water pooling, or other acts of God.
- d) Purchaser's abuse, including but not limited to neglect; failure to operate, use or maintain the product in accordance with the instructions provided with the product.
- e) Any component not sold or manufactured by Carefree.
- f) Any failure that results from the use of another manufacturer's product with a Carefree product that is not specifically approved by Carefree.
- g) Any incidental, indirect, or consequential loss, damage, or expense that may result from any defect, failure, or malfunction of the Carefree product.
- h) The removal or alteration of any product component or device. In the event of such removal or alteration, this warranty is void.
- i) Any expense related to delivery or pick-up of product to/from the service dealer.

### 4. RESPONSIBILITIES OF THE PURCHASER

IN ORDER FOR THE WARRANTY TO BE HONORED, THE PURCHASER MUST HAVE PROOF OF PURCHASE: THE ORIGINAL RECEIPT OR THE WARRANTY CARD ON FILE AT CAREFREE OF COLORADO. FAILURE TO PROVIDE THE REQUIRED DOCUMENTATION MAY DELAY OR VOID ANY WARRANTY CLAIM.

- a) Retain dated proof of purchase for specified product, and provide it as requested.
- b) Inspect the product upon purchase to confirm the condition and proper operation of the product.
- c) Perform "Periodic Maintenance" as specified in Owners Manual.
- d) Use reasonable care in maintenance, operation, use and storage of the product in accordance with the instructions contained in the owner's manual.

### 5. WARRANTY CLAIM PROCEDURE

- a) Deliver any product claimed or found defective during warranty period to a Carefree of Colorado Authorized Service Dealer. Visit [www.carefreeofcolorado.com](http://www.carefreeofcolorado.com) for the name of nearest Authorized Service Dealer, or call Carefree at the phone number shown.
- b) Customer shall schedule a time with an Authorized Service Dealer. Repair or replacement will be scheduled and performed at the Authorized Service Dealer according to normal work flow and availability of replacement parts.
- c) *Work must be performed by a Carefree authorized service center.* When warranty work/repair is performed by an authorized service agent, the agent is responsible for directly billing Carefree of Colorado for warranted parts and labor.
- d) Carefree shall pay the respective servicing dealer or agent for performing any repairs authorized by Carefree as per the terms of this warranty. Company will allow for freight and labor charges - labor is based on Flat Rate Form.
- e) All warranty claims shall be paid through the servicing agent. Carefree does not provide reimbursement for warranty claims paid for by the customer.
- f) The customer shall pay only those costs not covered by warranty. The customer shall have no out-of-pocket expenses except as stated.
- g) The Original Purchaser is responsible for any expenses related to delivery or pick up of product to/from the Service Dealer.
- h) If the Purchaser does not receive satisfactory results from the Authorized Service Dealer, the Purchaser should contact the Carefree of Colorado Customer Care Department within 10 days after completion of the questionable service.

**THIS WARRANTY GIVES THE OWNER SPECIFIC LEGAL RIGHTS. THE LAWS OF CERTAIN JURISDICTIONS MAY GRANT THE OWNER ADDITIONAL RIGHTS AND PRIVILEGES.** Except as set forth above, Carefree makes no warranty, whether statutory or otherwise, including without limitation, any warranty of merchantability or fitness for a particular purpose. Carefree shall have no liability except to repair, replace or adjust defective products and parts. Carefree specifically excludes any liability, whether in contract, tort or otherwise, for personal injury, property damage, economic or consequential losses. Carefree has not authorized any person or company to alter the terms of this warranty.

It is Carefree of Colorado's policy and practice to continuously improve the company's products and services. Therefore, Carefree reserves the right to make changes in design and components, without notice, whenever it is believed the quality of the product will be improved, but without incurring any obligation to incorporate such improvements in any product which has been shipped or in service.

