



**ANEMOMETER DISCONTINUED**

**PLEASE FORWARD TO:**

**Dealer Service**

**SERVICE MANAGER**    **WARRANTY MANAGER**    **PARTS MANAGER**

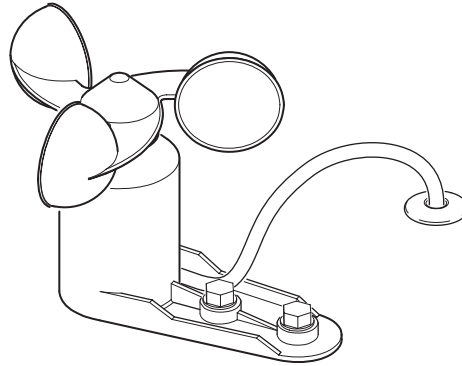

The anemometer that was used with the 12V Windsmart (Eclipse, One-Touch) and the 110V auto-retract system (Mirage) is no longer available. The part is discontinued and no longer manufactured.

For repair purposes, there are two options for the customer.

1. Remove the anemometer from the RV. The system will still operate as an electric awning with the normal extend and retract functions. There would be no auto-retract feature.

If removing the anemometer, make sure to seal any exposed wires and mounting holes.

2. For Eclipse and Mirage, upgrade the system with the Direct Response Auto-Retract System. This system is not available for the One-Touch.

**Order Information:**

SR0036 - 12V Direct Response - Eclipse

SR0035 - 110V Direct Response - Mirage

*These kits do not include the optional remote. If upgrading a current system that has a remote, also order the remote upgrade kit.*

SR0014 - Remote Upgrade Kit (433MHz)