



ROLLER REPLACEMENT KIT, TRAVEL'R

Dealer Service

The roller replacement kit (p/n R001697) provides a means of replacing the lower arm rollers for the Travel'r when the rollers become damaged or missing. An end stop is also provided to close the end of the rear extrusion.

Instructions are reproduced below and included with the kit.

NOTE: The views shown are looking from the ground up to the arm.

CAUTION Wrap the surfaces of any tools with tape or other suitable material to prevent damage to the finish of the awning components. Damage that occurs while installing the rollers is not considered a warrantable claim.

1. Open the awning approximately 6".
2. Disengage power to the awning.
3. If the rollers are missing:
 - 3.1. Carefully press the arm to one side while pulling the opposite side of the arm out until the roller pin is clear of the roller channel.
 - 3.2. Press the opposite side of the arm while pulling until the second pin is out of the channel.
4. If one or more rollers are still attached:
 - 4.1. Place a flat blade screwdriver or similar tool between the rear extrusion and the outer arm on one side.
 - 4.2. Using the screwdriver, carefully press the channel and arm until the roller can be pulled from the roller channel.
 - 4.3. Press the opposite side of the arm while pulling until the second pin or roller is out of the roller channel.
 - 4.4. Remove the existing rollers from the roller pins if still attached.
5. Slide the new rollers onto the roller pins (2 per arm).
6. Carefully twist the arm sideways to place the first roller into the channel of the rear extrusion.
7. Place a flat blade screwdriver or similar tool between the rear extrusion and the outer arm
8. Using the screwdriver, carefully press the channel and arm until the roller can be pushed into the roller channel.
9. The screwdriver may slightly deform the rear extrusion. If this happens, open the awning and using the screwdriver or a pair of channel locks, carefully bend the extrusion back into shape.
10. Press the end stop up into the rear channels of the extrusion. The tabs will click into the slots in the rear extrusion.

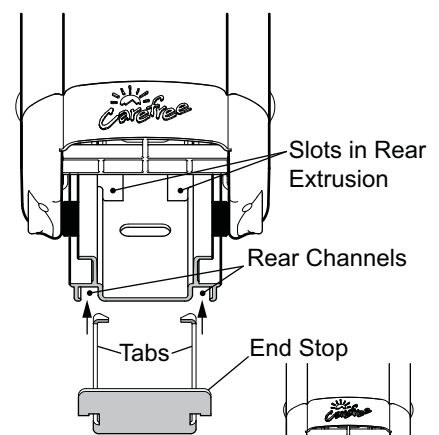
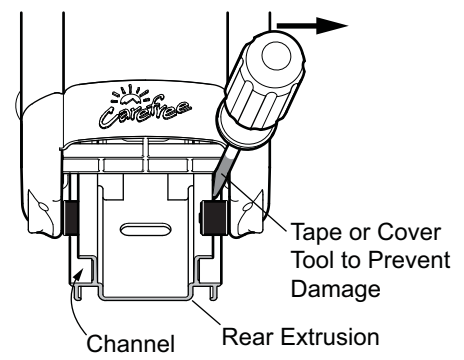
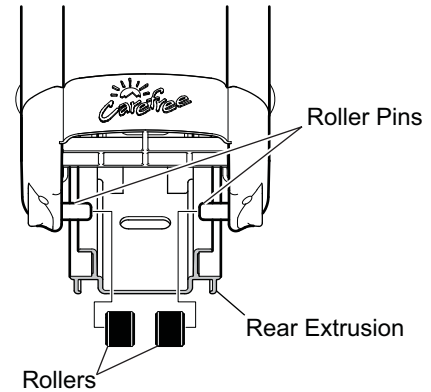

Installation Complete
TravelR056d